



INTORQ

setting the standard

INTORQ BFK458

Electromagnetically-released spring-applied brake

Operating Instructions

This documentation applies to ...

BFK458-06...25

Single version

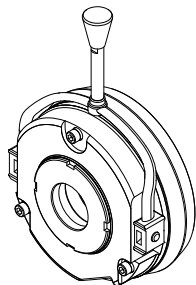

BFK458XX_XXX.iso/dms

Double version

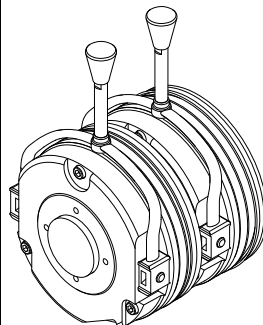

BFK458XX_XXX.iso/dms

Product key

Product key

INTORQ B FK □□□ - □□ □



Legend for the product key INTORQ BFK458

A	Product group	Braking
B	Product family	Spring-applied brake
C	Type	458
D	Size	06, 08, 10, 12, 14, 16, 18, 20, 25
E	Design	E - adjustable (brake torque can be reduced via adjuster nut) N - not adjustable

Not coded: Supply voltage, hub bore, options

Identification

Package label				Example			
Manufacturer		Bar code					
Type (see product key)		Type-No.					
Name							
Rated voltage	Rated brake torque	Qty. per box					
Rated power	Hub diameter	Packaging date					
Supplement		CE mark					

BFK458-017.iso/dms

Nameplate

Content				Example			
Manufacturer		CE marking					
Brake type							
Rated voltage	Rated power	Hub diameter					
Type no.	Rated torque	Date of manufacture					

Document history

Material number	Version			Description
405520	1.0	08/1998	TD09	Initial edition for series
405520	1.1	05/2000	TD09	Address revision Changed values of brake torques in Tab. 1 and Tab. 3 Supplementation of Tab. 4, "operating times"
460730	2.0	11/2002	TD09	All chapters: Completely revised Change of company name Changed values of brake torques Amendment of drawings, Fig. 12, Fig. 13, Fig. 14, Fig. 15 and Fig. 16 New: Chapter 7.4 "Spare parts list for double spring-operated brake"
13040626	2.1	02/2005	TD09	Change of company name to INTORQ
13284675	3.0	01/2009	TD09	Change of tightening torques Supplementation of Tab. 5 Revision of chapter 3.5 Supplementation of chapter 7.1 and 7.2
13284675	3.1	01/2010	TD09	Change of the maintenance intervals for holding brakes with emergency stop
13343893	4.0	07/2010	TD09	Values of brake torque and speed modified (Tab. 3)
13343893	4.1	05/2012	TD 09	Property class of the fixing screws changed
13343893	5.0	10/2013	TD 09	Complete revision

i Contents

1	Preface and general information	6
1.1	About these Operating Instructions	6
1.2	Terminology used	6
1.3	Conventions used	6
1.4	Abbreviations used	7
1.5	Notes used	8
1.6	Scope of supply	9
1.7	Disposal	9
1.8	Drive systems	9
1.9	Legal regulations	10
2	Safety instructions	11
2.1	General safety information	11
2.2	Application as directed	12
3	Technical data	13
3.1	Product description	13
3.2	Characteristics	15
3.3	Operating times	21
3.4	Friction work / operating frequency	23
3.5	Emission	24
4	Mechanical installation	25
4.1	Overview	25
4.2	Important notes	25
4.3	Necessary tools	26
4.4	Mounting	27
4.5	Installation	27
5	Electrical installation	35
5.1	Electrical connection	35
5.2	Bridge/half-wave rectifiers (option)	38
6	Commissioning and operation	41
6.1	Important notes	41
6.2	Function checks before commissioning	41
6.3	Commissioning	45
6.4	During operation	45

i Contents

7	Maintenance/repair	47
	7.1 Wear of spring-applied brakes	47
	7.2 Inspections	48
	7.3 Maintenance	48
	7.4 Spare-parts list	52
	7.5 Spare parts order	54
8	Troubleshooting and fault elimination	56

1 Preface and general information

1.1 About these Operating Instructions





- These Operating Instructions will help you to work safely on and with the spring-applied brake with electromagnetic release. They contain safety instructions that must be followed.
- All persons working on or with the electromagnetically released spring-applied brakes must have the Operating Instructions available and observe the information and notes relevant for them.
- The Operating Instructions must always be in a complete and perfectly readable condition.

1.2 Terminology used

	Term	In the following text used for
	Spring-applied brake	Spring-applied brake with electromagnetic release
	Drive system	Drive systems with spring-applied brakes and other drive components

1.3 Conventions used

This documentation uses the following conventions to distinguish different types of information:

Spelling of numbers	Decimal separator	Point	The decimal point is always used. For example: 1234.56
	Symbols	Page reference	
Document reference			Reference to another documentation with additional information For example:  Operating instructions
Wildcard			Wildcard for options, selections For example: BFK458-  = BFK458-10

1 Preface and general information

1.4 Abbreviations used

Letter symbol	Unit	Name
I	A	Current
I_H	A	Holding current, at 20 °C and withstand voltage
I_L	A	Release current, at 20 °C and release voltage
I_N	A	Rated current, at 20 °C and rated voltage
M_A	Nm	Tightening torque of the fixing screws
M_K	Nm	Characteristic torque of the brake, characteristic value of a relative speed of 100 rpm
n_{max}	rpm	Maximum occurring speed during the slipping time t_3
P_H	W	Coil power during holding, at voltage change-over and 20 °C
P_L	W	Coil power during release, at voltage change-over and 20 °C
P_N	W	Rated coil power, at rated voltage and 20 °C
Q	J	Quantity of heat/energy
Q_E	J	Maximally permissible friction energy for one-time switching, thermal parameter of the brake
Q_R	J	Braking energy, friction energy
Q_{Smax}	J	Maximally permissible friction energy for cyclic switching, depending on the operating frequency
R_m	N/mm ²	Tensile strength
R_N	Ohms	Rated coil resistance at 20 °C
R_z	µm	Averaged surface roughness
S_h	1/h	Operating frequency, i.e. the number of switching operations evenly spread over the time unit
S_{hue}	1/h	Transition operating frequency, thermal parameter of the brake
S_{hmax}	1/h	Maximally permissible operating frequency, depending on the friction energy per switching operation
s_L	mm	Air gap, i.e. lift of the armature plate while the brake is switched
s_{LN}	mm	Rated air gap
s_{Lmin}	mm	Minimum air gap
s_{Lmax}	mm	Maximum air gap
t_1	ms	Engagement time, sum of the delay time and braking torque rise time $t_1 = t_{11} + t_{12}$
t_2	ms	Disengagement time, time from switching the stator until reaching 0.1 M_{rated}
t_3	ms	Slipping time, operation time of the brake (according to t_{11}) until standstill
t_{11}	ms	Delay time during engagement, time from voltage switch-off to the start of torque rise
t_{12}	ms	Rise time of the braking torque, time from the start of torque rise until reaching the braking torque
t_{ue}	s	Overexcitation time
U	V	Voltage
U_H	V DC	Withstand voltage, during voltage change-over
U_L	V DC	Release voltage, during voltage change-over
U_N	V DC	Rated coil voltage; in the case of brakes requiring a voltage change-over, U_{rated} equals U_L

1 Preface and general information

1.5 Notes used

The following pictographs and signal words are used in this documentation to indicate dangers and important information:

Safety instructions



Structure of safety instructions:

 **Danger!**
 Characterises the type and severity of danger



Note
 Describes the danger

Possible consequences:
 ■ List of possible consequences if the safety instructions are disregarded.

Protective measure:
 ■ List of protective measures to avoid the danger.

Pictograph and signal word	Meaning
 Danger!	Danger of personal injury through dangerous electrical voltage Reference to an imminent danger that may result in death or serious personal injury if the corresponding measures are not taken.
 Danger!	Danger of personal injury through a general source of danger Reference to an imminent danger that may result in death or serious personal injury if the corresponding measures are not taken.
 Stop!	Danger of property damage Reference to a possible danger that may result in property damage if the corresponding measures are not taken.

Application notes

Pictograph and signal word	Meaning
 Note!	Important note to ensure troublefree operation
 Tip!	Useful tip for simple handling
	Reference to another documentation

1 Preface and general information

1.6 Scope of supply

After receipt of the delivery, check immediately whether it corresponds to the accompanying papers. INTORQ does not grant any warranty for deficiencies claimed subsequently.

- Claim visible transport damage immediately to the forwarder.
- Claim visible deficiencies / incompleteness immediately to INTORQ GmbH & Co.KG.

1.7 Disposal

The spring-applied brake consists of different types of material.

- Recycle metals and plastics.
- Ensure professional disposal of assembled PCBs according to applicable environmental regulations.

1.8 Drive systems

Labelling

Drive systems and components are unambiguously designated by the indications on the nameplate.

Manufacturer: INTORQ GmbH & Co KG, Wülmser Weg 5, D-31855 Aerzen

- The spring-applied INTORQ brake is also delivered in single modules and individually combined to its modular design. The data - package labels, nameplate, and type code in particular - apply to one complete stator.
- If single modules are delivered, the labelling is missing.

1 Preface and general information

1.9 Legal regulations

Liability

- The information, data and notes in this documentation met the state of the art at the time of printing. Claims referring to products which have already been supplied cannot be derived from the information, illustrations and descriptions.
- We do not accept any liability for damage and operating interference caused by:
 - inappropriate use
 - unauthorised modifications to the product
 - improper working on and with the product
 - operating faults
 - disregarding the documentation

Warranty

- Terms of warranty: see terms of sale and delivery of INTORQ GmbH & Co. KG.
- Warranty claims must be made to INTORQ immediately after detecting defects or faults.
- The warranty is void in all cases where liability claims cannot be made.

2 Safety instructions

2.1 General safety information

- INTORQ components ...
 - ... must only be applied as directed.
 - ... must not be commissioned if they are noticeably damaged.
 - ... must not be technically modified.
 - ... must not be commissioned if they are mounted and connected incompletely.
 - ... must not be operated without the required covers.
 - ... can hold live as well as moving or rotary parts during operation according to their degree of protection. Surfaces may be hot.
- For INTORQ components ...
 - ... the documentation must always be kept at the installation site.
 - ... only permitted accessories are allowed to be used.
 - ... only original spare parts of the manufacturer are allowed to be used.
- All specifications of the corresponding enclosed documentation must be observed.
This is vital for a safe and trouble-free operation and for achieving the specified product features.
- Only qualified, skilled personnel are permitted to work on and with INTORQ components.
In accordance with IEC 60364 or CENELEC HD 384, qualified, skilled personnel are persons ...
 - ... who are familiar with the installation, mounting, commissioning, and operation of the product.
 - ... who have the qualifications necessary for their occupation.
 - ... who know and apply all regulations for the prevention of accidents, directives, and laws relevant on site.
- Risk of burns!
 - Surfaces may be hot during operation! Provide for protection against accidental contact.
- Risk of injury due to a rotating shaft!
 - Wait until the motor is at standstill before you start working on the motor.
- The friction lining and the friction surfaces must by no means have contact to oil or grease since even small amounts reduce the brake torque considerably.
- The brake is designed for operation under the environmental conditions that apply to IP54. Because of the numerous possibilities of using the brake, it is however necessary to check the functionality of all mechanical components under the corresponding operating conditions.

2 Safety instructions

2.2 Application as directed

- INTORQ components ...
 - ... are intended for use in machinery and systems.
 - ... must only be used for the purposes ordered and confirmed.
 - ... must only be operated under the ambient conditions prescribed in these Operating Instructions.
 - ... must not be operated beyond their corresponding power limits.

Any other use shall be deemed inappropriate!

Possible applications of the INTORQ spring-applied brake

- Humidity: no restrictions
 - In case of formation of condensed water and moisture: provide for appropriate ventilation to ensure that all components will dry quickly.
- Ambient temperature:
 - -20 °C to +40 °C (standard)
- At high humidity and low temperature:
 - Take measures to protect armature plate and rotor from freezing.
- Protect electrical connections against contact.

3 Technical data

3.1 Product description

3.1.1 Structure and function

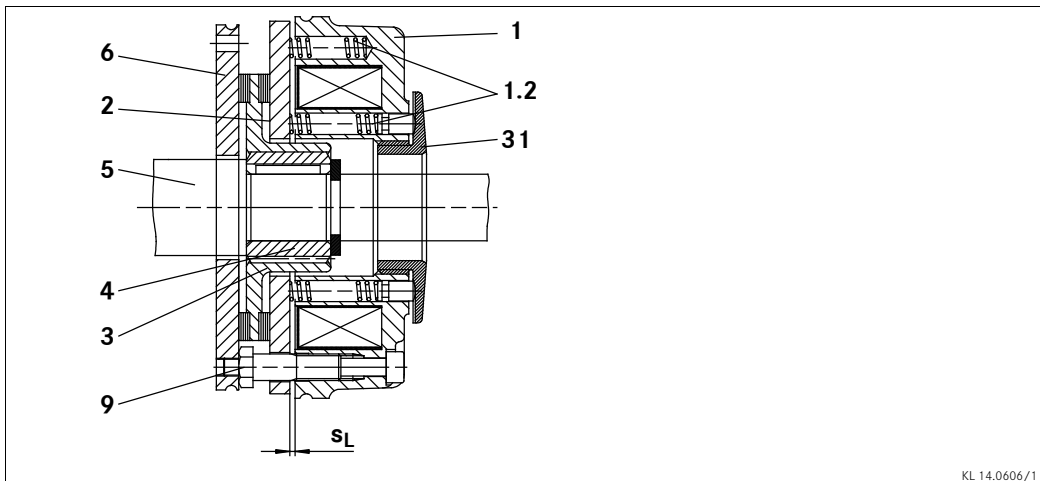

Fig. 1 Design of the spring-applied brake INTORQ BFK458: basic module E (complete stator) + rotor + hub + flange

- | | | | | | |
|-----|---------------------|---|-------|-------|------------------------|
| 1 | Complete stator | 3 | Rotor | 6 | Flange |
| 1.2 | Compression springs | 4 | Hub | 9 | Sleeve bolts |
| 2 | Armature plate | 5 | Shaft | 31 | Torque adjustment ring |
| | | | | s_L | Air gap |

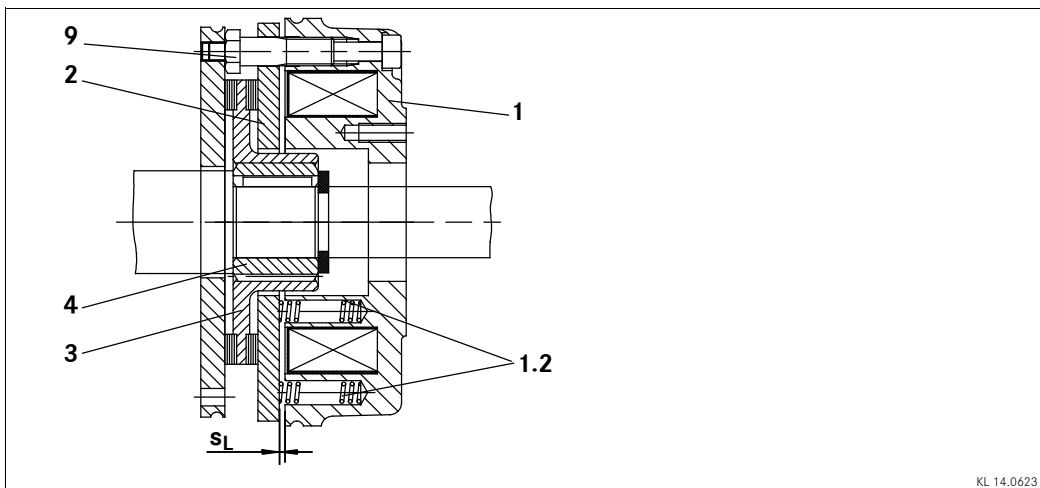

Fig. 2 Design of the spring-applied brake INTORQ BFK458: basic module N (complete stator) + rotor + hub + flange

- | | | | | | |
|-----|--------------------|---|--------------|-------|---------|
| 1 | Complete stator | 3 | Rotor | s_L | Air gap |
| 1.2 | Compression spring | 4 | Hub | | |
| 2 | Armature plate | 9 | Sleeve bolts | | |

3 Technical data

This spring-applied brake is a single-disk brake with two friction surfaces. The braking torque is generated by several compression springs (1.2) by friction locking. The brake is released electromagnetically.

The spring-applied brake INTORQ BFK458-□□ is a single-disk brake with two friction surfaces. Several compression springs (1.2) create the braking torque by friction locking. The brake is released electromagnetically.

The spring-applied brake is designed for the conversion of mechanical work and kinetic energy into heat. For operating speed, see chapter 3.2 Rated data. Due to the static brake torque, the brake can hold loads without speed difference. Emergency braking is possible at high speed, see chapter 3.2 Rated data. The more friction work, the higher the wear.

3.1.2 Braking

During braking the rotor (3) axially slidable on the hub (4) is pressed against the friction surface by the inner and outer springs (1.2) via the armature plate. The asbestos-free friction linings ensure a high braking torque and low wear. The braking torque transmission between hub (4) and rotor (3) is effected by means of toothing.

3.1.3 Brake release

In the braked state, there is an air gap "s_L" between the stator (1) and the armature plate (2). To release the brake, the coil of the stator (1) is excited with the DC voltage provided. The magnetic force generated attracts the armature plate (2) towards the stator (1) against the spring force. The rotor (3) is then released and can rotate freely.

3.1.4 Brake torque reduction

For basic module E (adjustable), the spring force and thus the brake torque can be reduced by unscrewing the adjuster nut (8), (□ 46).

3.1.5 Manual release (optional)

The manual release is optionally available for short-term releases when no voltage is applied. The manual release can be retrofitted.

3.1.6 Microswitch (optional)

The manufacturer offers the microswitch for air-gap or wear monitoring. The user must provide the corresponding electrical connection (□ 35et seqq.).

When air-gap monitoring, the motor does not start before the brake has been released. With this set-up, all possible faults are monitored. For example, in the event of defective rectifiers, interrupted connection cables, defective coils, or excessive air gaps the motor will not start.

When checking the wear, no current will be applied to the brake and the motor if the air gap is too large.

3 Technical data

3.1.7 Encapsulated design (optional)

This design not only avoids the penetration of spray water and dust, but also the spreading of abrasion particles outside the brake. This is achieved by:

- a cover seal over the armature plate and rotor,
- a cover in the adjuster nut,
- a shaft seal in the adjuster nut for continuous shafts (option).

3.1.8 Project planning notes

- The brakes are dimensioned in such a way that the given characteristic torques are reached safely after a short run-in process.
- Due to the fluctuating properties of the organic friction linings used and the alternating environmental conditions, deviations of the given braking torques may occur. These must be considered by corresponding safety measures in the dimensioning process. Especially with humidity and alternating temperatures, an increased breakaway torque may occur after a long downtime.
- If the brake is used as a pure holding brake without dynamic load, the friction lining must be reactivated regularly.

3.2 Characteristics

General data





Stop!

Please observe that engagement times and disengagement times change depending on the brake torque.



3 Technical data

Size	06	08	10	12	14	16	18	20	25	
Rated torques [Nm], relating to the relative speed $\Delta n = 100 \text{ rpm}$								80 E		
	1.5 E	3.5 N/E				25 N/E	35 N/E	65 N/E	115 N/E	175 N/E
	2 N/E	4 E	7 N/E	14 N/E	35 N	45 N/E	80 N/E	145 N/E	220	
	2.5 N/E	5 N/E	9 N/E	18 N/E	40 N/E	55 N/E	100 N/E	170 N/E	265 N/E	
	3 N/E	6 N/E	11 N/E	23 N/E	45 N/E	60 N/E	115 N/E	200 N/E	300 N/E	
	3.5 N/E	7 N/E	14 N/E	27 N/E	55 N/E	70 N/E	130 N/E	230 N/E	350 N/E	
	4 N/E	8 N/E	16 N/E	32 N/E	60 N/E	80 N/E	150 N/E	260 N/E	400 N/E	
	4.5 N/E	9 N/E	18 N/E	36 N/E	65 N/E	90 N/E	165 N/E	290 N/E	445 N/E	
	5 E	10 E	20 E	40 E	75 N/E	100 N/E	185 N/E	315 N/E	490 N/E	
	5.5 E	11 E	23 N/E	46 N/E	80 N/E	105 N/E	200 N/E	345 N/E	530 N/E	
	6 N/E	12					125 N/E	235 N/E	400 N/E	600 N/E

**Tab. 1 N.....Brake torque for module N (without torque adjustment ring)
E.....Brake torque for module E (with torque adjustment ring)**

	Holding brake with emergency stop operation (s_{Lmax} . approx. $1.5 \times s_{Lrated}$)
	Service brake (s_{Lmax} . approx. $2.5 \times s_{Lrated}$)
	Standard braking torque

3.2.1 Basic module E, brake torque reduction

For basic module E, the braking torque can be reduced by means of the torque adjustment ring in the stator. The torque adjustment ring must only be screwed out up to the maximum projection "h_{Emax.}",  15 and  46.

Size	06	08	10	12	14	16	18	20	25
Torque reduction per detent [Nm]	0.2	0.35	0.8	1.3	1.7	1.6	3.6	5.6	6.2

Tab. 2

3 Technical data

3.2.2 Brake torques depending on the speed and permissible limit speeds

Type	Rated torque at $\Delta n = 100$ rpm [%]	Braking torque at Δn_0 [rpm] [%]			max. speed $\Delta n_{0max.}$ with horizontal mounting position [rpm]
		1500	3000	maximum	
BFK458-06	100	87	80	74	6000
BFK458-08		85	78	73	5000
BFK458-10		83	76		4000
BFK458-12		81	74		3600
BFK458-14		80	73	72	
IBFK458-16		79	72	70	
IBFK458-18		77	70	68	
BFK458-20		75	68	66	3000
BFK458-25		73	66		

Tab. 3 Brake torques depending on the speed and permissible limit speeds

Type	s_{LN} +0.1 mm -0.05 mm [mm]	$s_{Lmax.}$ Service brake [mm]	$s_{Lmax.}$ Holding brake [mm]	Max. adjustment, permissible wear distance [mm]	Rotor thickness		Excess of the torque adjustment ring $h_{Emax.}$ [mm]
					min. ¹⁾ [mm]	max. [mm]	
BFK458-06	0.2	0.5	0.3	1.5	4.5	6.0	4.5
BFK458-08					5.5	7.0	
BFK458-10					7.5	9.0	
BFK458-12	0.3	0.75	0.45	2.0	8.0	10.0	9.5
BFK458-14				2.5	7.5		11
BFK458-16				3.5	8.0	11.5	10
BFK458-18	0.4	1.0	0.6	3.0	10.0	13.0	15
BFK458-20				4.0	12.0	16.0	17
BFK458-25	0.5	1.25	0.75	4.5	15.5	20.0	19.5

3 Technical data

Type	Pitch circle		Screws for flange mount. DIN912 8.8 2)	Minimum depth of clearing holes (mounting flange) [mm]	Tightening torque		Weight of complete stator [kg]
	Ø[mm]	Thread			Screws [Nm]	Complete lever [Nm]	
BFK458-06	72	3 x M4	3 x M4	0.5	3.0	2.8	0.75
BFK458-08	90	3 x M5	3 x M5	1	5.9		1.2
BFK458-10	112	3 x M6	3 x M6	2	10.1	4.8	2.1
BFK458-12	132	3 x M6	3 x M6	3			3.5
BFK458-14	145	3 x M8	3 x M8	1.5	24.6	12	5.2
BFK458-16	170			0.5			7.9
BFK458-18	196	6 x M8	4 x M8 ³⁾	0.8			23
BFK458-20	230	6 x M10	4 x M10 ³⁾	2.1	48	19.3	
BFK458-25	278		6 x M10	5			40

Tab. 4 Characteristics of INTORQ BFK458 spring-applied brake

- 1) The friction lining is designed such that the brake can be adjusted at least 5 times.
- 2) The screw length is dependent on the material and the thickness of the mounting surface provided by the customer.
- 3) The threads are positioned in the mounting surface, offset 30° each to the centre axis of the hand-release lever.

3 Technical data

Type	Electrical power $P_{20}^{1)}$	Rated current I_N	Release voltage/holding voltage U	Coil resistance $R_{20} \pm 8\%$
	[W]	[A]	[V]	[Ω]
BFK458-06	20	0.83	24	20
		0.21	96	460.8
		0.194	103	530.5
		0.114	170	1445
		0.111	180	1620
		0.105	190	1805
		0.098	205	2101
BFK458-08	25	1.04	24	23
		0.26	89	368
		0.242	103	424.4
		0.147	170	1156
		0.138	180	1296
		0.131	190	1444
		0.121	205	1681
BFK458-10	30	1.25	24	19.2
	31	0.322	96	297.3
	32	0.31	103	331.5
	30	0.176	170	963.3
	32	0.177	180	1013
	30	0.157	190	1203
	33	0.160	205	1273
BFK458-12	40	1.66	24	14.4
		0.41	96	230.4
		0.388	103	265.2
		0.235	170	722.5
		0.222	180	810
		0.210	190	902.5
		0.195	205	1051
BFK458-14	50	2.08	24	11.5
		0.52	96	184.3
	53	0.514	103	200.2
	50	0.294	170	578
	53	0.294	180	611.3
	50	0.263	190	722
	53	0.258	205	792.9
BFK458-16	55	2.29	24	10.5
		0.573	96	167.6
	56	0.543	103	189.5
	55	0.323	170	525.5
		0.305	180	589.1
	60	0.315	190	601.7
	56	0.292	205	750.5

3 Technical data

Type	Electrical power P_{20} ¹⁾	Rated current I_N	Release voltage/holding voltage U	Coil resistance $R_{20} \pm 8\%$
	[W]	[A]	[V]	[Ω]
BFK458-18	85	3.54	24	6.8
		0.885	96	108.4
		0.825	103	124.8
		0.5	170	340
		0.472	180	387.2
		0.447	190	424.7
		0.414	205	494.4
BFK458-20	100	4.16	24	5.76
		1.04	96	92.2
		0.970	103	106.1
		0.588	170	289
		0.55	180	324
		0.487	205	420.3
	110	0.578	190	328.2
BFK458-25	110	4.58	24	5.24
		1.14	96	83.8
		1.06	103	96.5
		0.647	170	262.7
		0.611	180	294.6
		0.578	190	328.2
		0.536	205	382.1

Tab. 5 Coil power

¹⁾ Coil power at 20°C

3 Technical data

3.3 Operating times

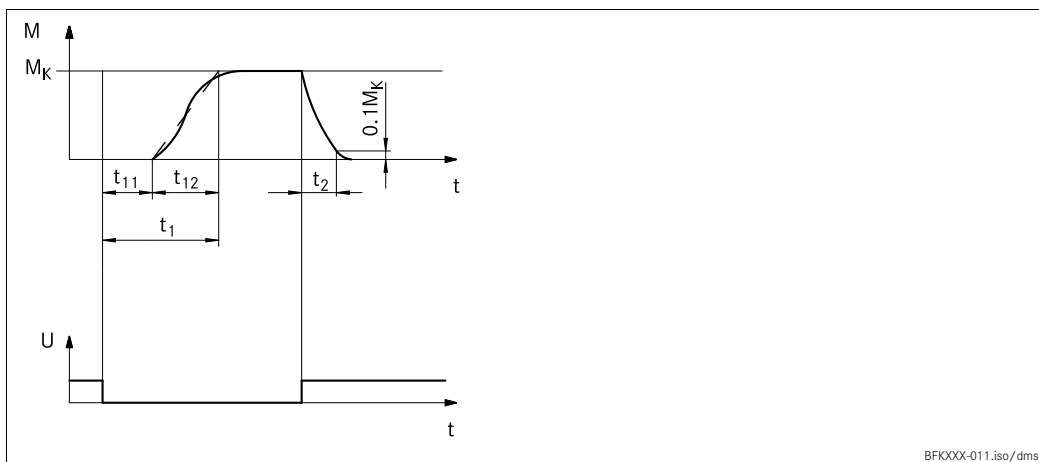

Fig. 3 Operating times of the spring-applied brakes

- t_1 Engagement time
- t_2 Disengagement time (up to $M = 0.1 M_K$)
- M_K Characteristic torque
- t_{11} Reaction delay during engagement
- t_{12} Rise time of the brake torque
- U Voltage

Type	Rated torque at $\Delta n = 100$ rpm M_r 1) [Nm]	Max. permissible friction work per operation only Q_E [J]	Transition operating frequency s_{hue} [h ⁻¹]	Operating times [ms] at s_{LN} and $0.7 I_N$			
				DC engagement			Disengage t_2
				t_{11}	t_{12}	t_1	
BFK458-06	4	3000	79	15	13	28	45
IBFK458-08	8	7500	50	15	16	31	57
BFK458-10	16	12000	40	28	19	47	76
BFK458-12	32	24000	30	28	25	53	115
BFK458-14	60	30000	28	17	25	42	210
BFK458-16	80	36000	27	27	30	57	220
BFK458-18	150	60000	20	33	45	78	270
BFK458-20	260	80000	19	65	100	165	340
BFK458-25	400	120000	15	110	120	230	390

Tab. 6 Switching energy - operating frequency - operating times

1) Minimum braking torque when all components are run in

3 Technical data

Engagement time

The transition from brake-torque free state to holding braking torque is not free of time lags.

Short brake engagement times are vital for emergency braking. DC switching together with a suitable spark suppressor must therefore be provided.

- The engagement times are valid for DC switching with a spark suppressor.
 - Spark suppressors are available for the rated voltages.
 - Connect the spark suppressors in parallel to the contact. If this is not admissible for safety reasons, e.g. with hoists and lifts, the spark suppressor can also be connected in parallel to the brake coil.
 - Circuit proposals:  35
- If the drive system is operated with a frequency inverter so that the brake will not be deenergised before the motor is at standstill, AC switching is also possible (not applicable to emergency braking).

Disengagement time

The disengagement time is the same for DC and AC switching. The disengagement times specified always refer to the control with overexcitation.

3 Technical data

3.4 Friction work / operating frequency

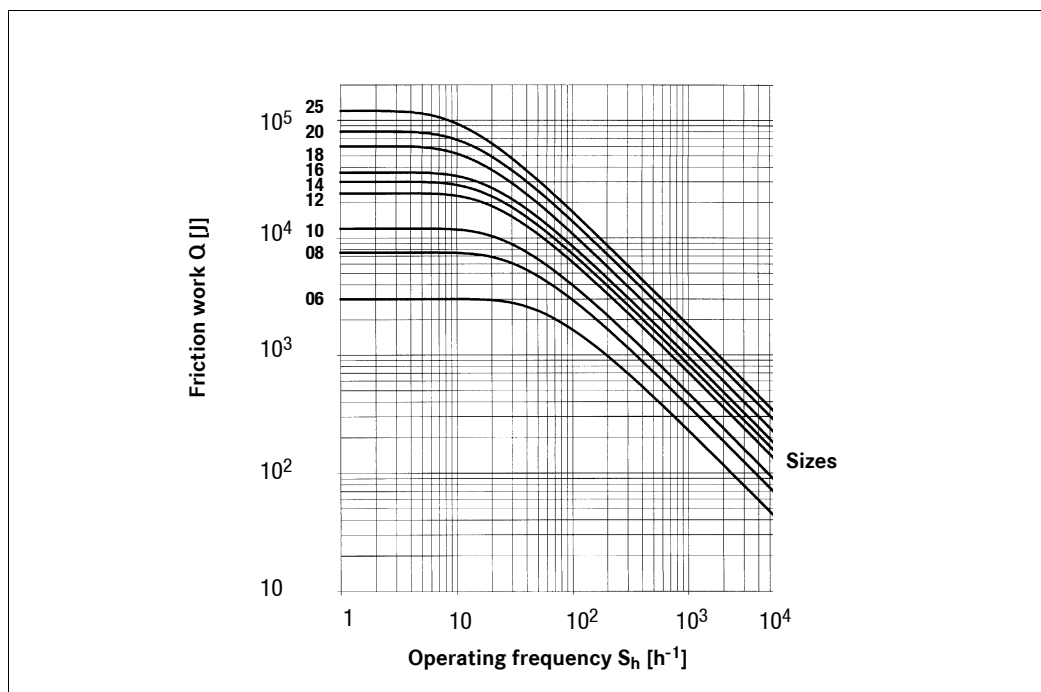

Fig. 4 Friction work as a function of the operating frequency

$$S_{h\max} = \frac{-S_{hue}}{\ln\left(1 - \frac{Q_R}{Q_E}\right)} \quad Q_{s\max} = Q_E \left(1 - e^{\frac{-S_{hue}}{S_h}}\right)$$

The permissible operating frequency $S_{h\max}$ depends on the quantity of heat Q_R (see Fig. 4). If the operating frequency S_h is specified, the permissible quantity of heat $Q_{s\max}$ will result.

With high speed and friction work, the wear increases strongly, because very high temperatures occur at the friction faces for a short time.

3 Technical data

3.5 Emission

Electromagnetic compatibility



Note!

The user must ensure compliance with EMC Directive 2004/108/EC using appropriate controls and switching devices.

If an INTORQ rectifier is used for the DC switching of the spring-applied brake and if the operating frequency exceeds five switching operations per minute, the use of a mains filter is required.

If the spring-applied brake uses a rectifier of another manufacturer for the switching, it may become necessary to connect a spark suppressor in parallel with the AC voltage. Spark suppressors are available on request, depending on the coil voltage.

Heat

Since the brake converts kinetic energy as well as mechanical and electrical energy into heat, the surface temperature varies considerably, depending on the operating conditions and possible heat dissipation. Under unfavourable conditions, the surface temperature can reach 130 °C.

Noises

The switching noises during engagement and disengagement depend on the air gap "s_L" and the brake size.

Depending on the natural oscillation after installation, operating conditions and state of the friction faces, the brake may squeak during braking.

Others

The abrasion of the friction parts produces dust.

4 Mechanical installation

4.1 Overview

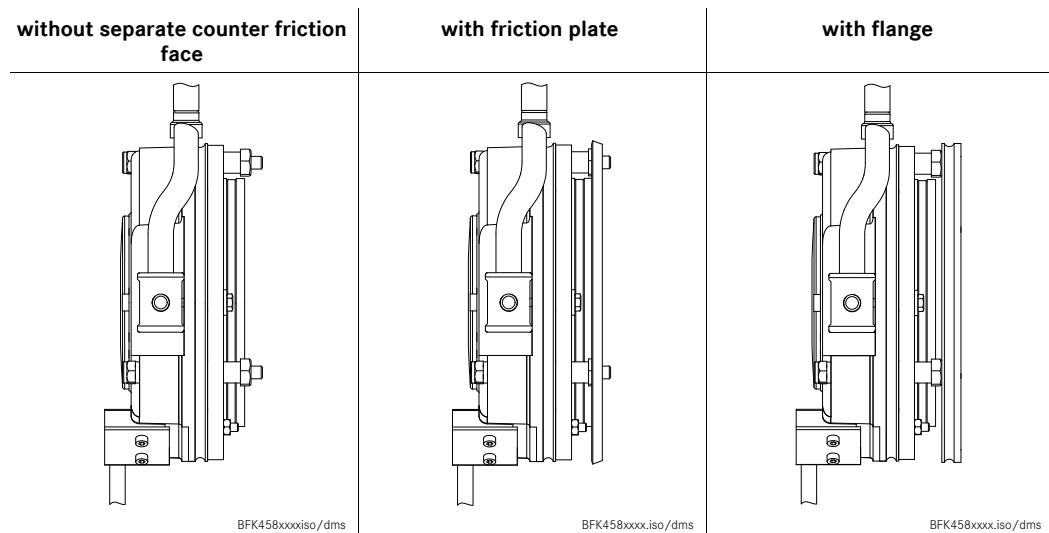

4.2 Important notes



Stop!

Toothed hub and screws must not be lubricated with grease or oil!

4.2.1 Design of end shield and motor shaft

- Comply with the mentioned minimum requirements regarding the end shield and the motor shaft to ensure a correct function of the brake.
- The diameter of the shaft shoulder must not be greater than the tooth root diameter of the hub.
- The form and position tolerances exclusively apply to the materials mentioned. If other materials are used, please contact INTORQ.
- The brake flange must be supported by the end shield across the full surface.







4 Mechanical installation

Minimum requirements for end shield:

- Material S235 JR , C15 or EN-GJL-250
 - Consult INTORQ if other materials are to be used.
- Evenness
 - Size 06 to 12: < 0.06 mm
 - From size 14: < 0.1 mm
- Axial runout 0.10 mm,
- Roughness Rz 10 to Rz 16
- Tensile strength $R_m \geq 250 \text{ N/mm}^2$
- Drill the threaded holes with the minimum thread depth (dimensions  18).
- The end shield must be free of grease and oil.

The diameter of the shaft shoulder must not be bigger than the tooth root diameter of the hub.

4.3 Necessary tools

Type	Torque key Insert for hexagon socket screws		Wrench size of open-jawed spanner [mm]			Hook wrench DIN 1810 design A	Box spanner for flange installation, outside	
	 Measuring range [Nm]	 Wrench size [mm]	 Sleeve bolts	 Nuts / bolts	 2-flat lever	 Diameter [mm]	 Wrench size [mm]	
BFK458-06	1 to 12	3 x 1/4" square	8	7 / 5,5	7	45 - 55	7 x 1/2" square	
BFK458-08		4 x 1/4" square	9	10 / 7		52 - 55	8 x 1/2" square	
BFK458-10		5 x 1/4" square	12			68 - 75	10 x 1/2" square	
BFK458-12			15	80 - 90				
BFK458-14	20 to 100	6 x 1/2" square	15	12 / 8	9	95 - 100	13 x 1/2" square	
BFK458-16				-	10	110 - 115		
BFK458-18					10	-	12	135 - 145
BFK458-20		17	-	14			155 - 165	17 x 1/2" square
BFK458-25								

* for flange mounting insertion with journal guide

4 Mechanical installation

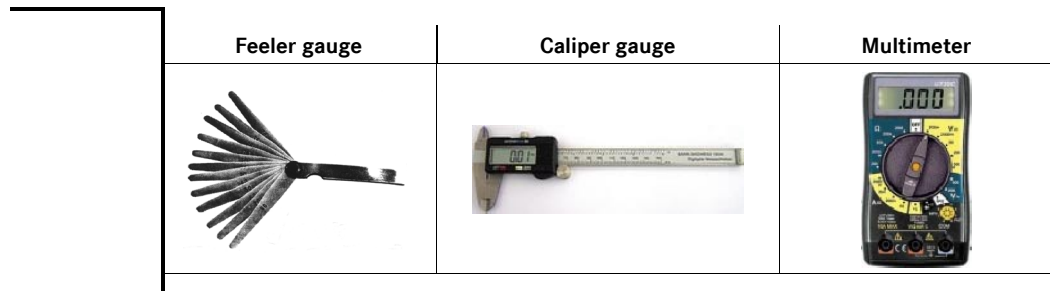

4.4 Mounting

4.4.1 Preparation

1. Unpack spring-applied brake.
2. Check for completeness.
3. Check nameplate data, especially rated voltage.

4.5 Installation

When you have ordered a version with manual release or flange, attach these units first.

4.5.1 Installation of the hub onto the shaft



Note!

The dimensioning of the shaft-hub connection is the responsibility of the customer. It must be ensured that the bearing length of the keyway is just as long as the length of the hub.

- Tensile strength of the hub material:
 - Size 06 - 16: Tensile strength $R_m > 460 \text{ N/mm}^2$
 - Size 18 - 25: Tensile strength $R_m > 650 \text{ N/mm}^2$

4 Mechanical installation



Stop!

Please note the following for the version "brake with shaft sealing ring in torque adjustment ring":

2. Lightly lubricate the lip of the shaft seal with grease.
3. When assembling the stator (1), push the shaft sealing ring carefully over the shaft.
 - The shaft should be located concentrically to the shaft seal.

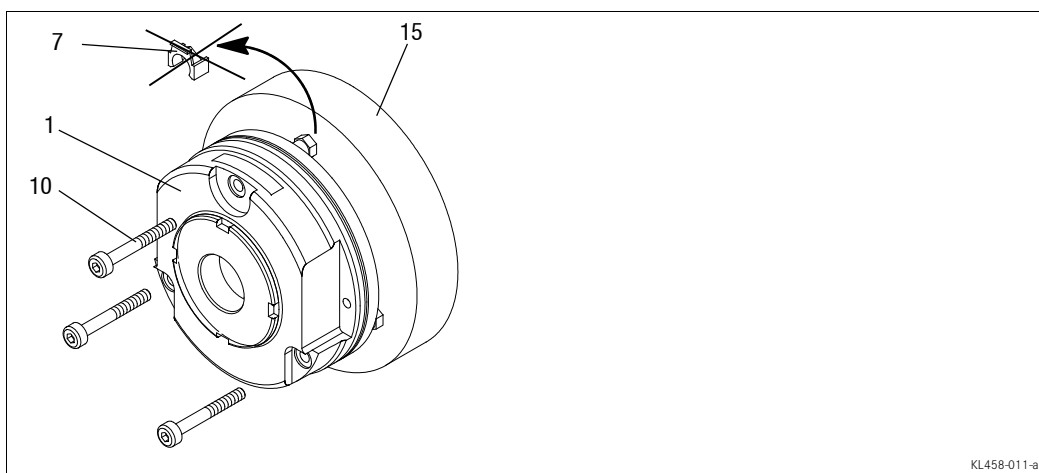

KL458-011-a

Fig. 7 Assembly of the spring-applied brake

1	Complete stator	10	Allen screw
7	Clip	15	Endshield

4. Screw the complete stator (1) onto the end shield (15) using the set of screws (10) provided and a torque key, (tightening torque 15).
5. Klemmsteine (7) entfernen und entsorgen.

4 Mechanical installation

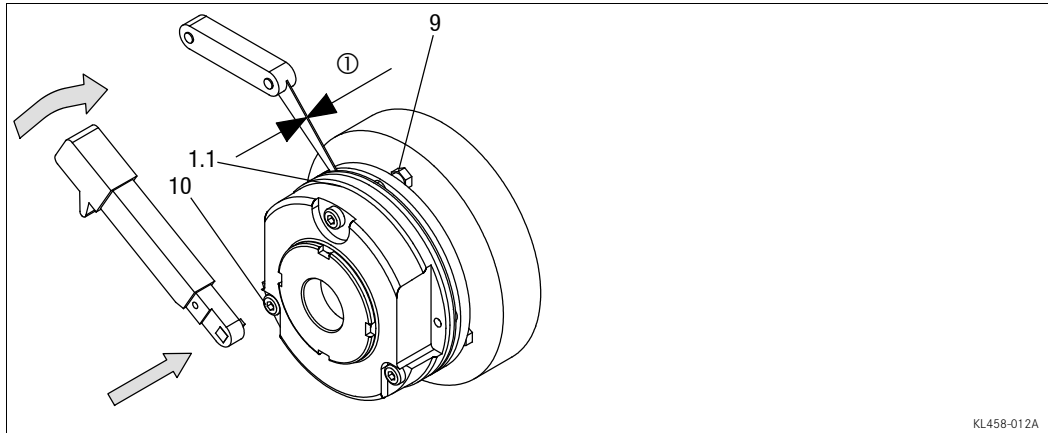

Fig. 8 Torque setting

- | | | |
|----------------------|---------------|------------|
| 7 Stator | 9 Sleeve bolt | ① s_{LN} |
| 10 Cheese head screw | | |

1. Check the air gap near the screws (10) by means of a feeler gauge and compare the values to the values for " s_{LN} " in the table (15).



Note!

Do not insert feeler gauge more than 10 mm between armature plate (2) and stator (1.1)!

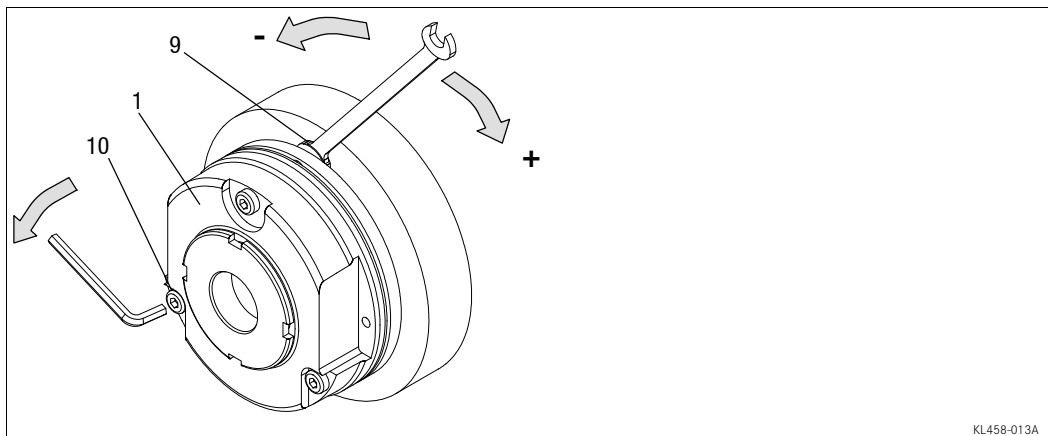

Fig. 9 Adjusting the air gap

- | | |
|-------------------|----------------------|
| 1 Complete stator | 10 Cheese head screw |
| 9 Sleeve bolt | |

If the measured value " s_L " is outside the tolerance of " s_{LN} ", set the dimension:

4 Mechanical installation

4.5.3 Assembly of the friction plate, sizes 06 to 16

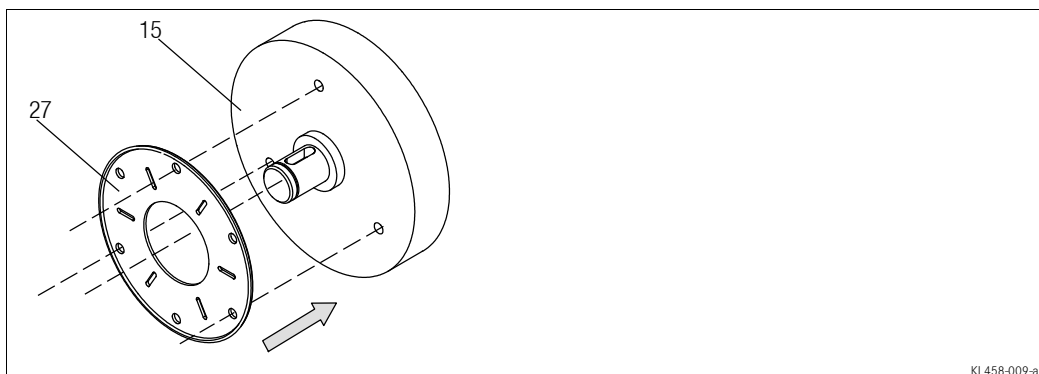

Fig. 10 Mounting the friction plate

15 End shield

27 Friction plate

1. Put a friction plate (27) **or** flange (6) against the end shield (15).



Note!

The flanged edge of the friction plate must remain visible!

2. Align pitch circle and fastening bore hole thread.

4.5.4 Assembly of the flange

The flange (6) can be screwed on the end shield (15) on the outer pitch circle (screw dimensions  15).

Mounting the flange with additional screws



Stop!

- Clearing holes for the screws in the end shield must be behind the threaded screw drill-holes in the flange. Without the clearing holes, minimal rotor thickness cannot be utilised. The screws must not press against the end shield. (See chapter 3.2 for clearing hole depth)
- For sizes 18 and 20, the fastening surface threading must be angled at 30° to the centre axis to the manual release lever.

4 Mechanical installation

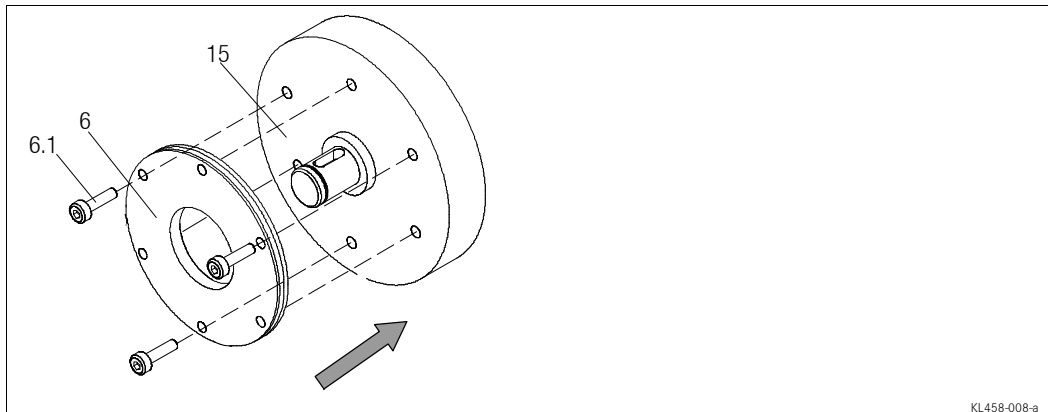

Fig. 11 Mounting the flange

6	Flange	15	End shield
6.1	Set of fastening screws		

1. Hold the flange (6) against the end shield (15) and check the pitch circle and retaining screw drill hole threading.
2. Fasten the flange (6) on the end shield (15) with the screws (6.1).
3. Tighten the cheese head screws (6.1) evenly, (tightening torques 15).
4. Check the height of the screw heads. The screw heads may not be higher than the minimum rotor thickness. We recommend using screws according to DIN 6912, dimensions 15.

Mounting the flange without additional screws



Stop!

When dimensioning the thread depth in the end shield, the permissible wear distance must be taken into consideration 15).

1. Hold the flange (6) against the end shield (15) and check the pitch circle and retaining screw drill hole threading.
2. Mount the brake with the set of screws provided for this purpose 28 and 52).

4 Mechanical installation

4.5.5 Assembly of the cover seal

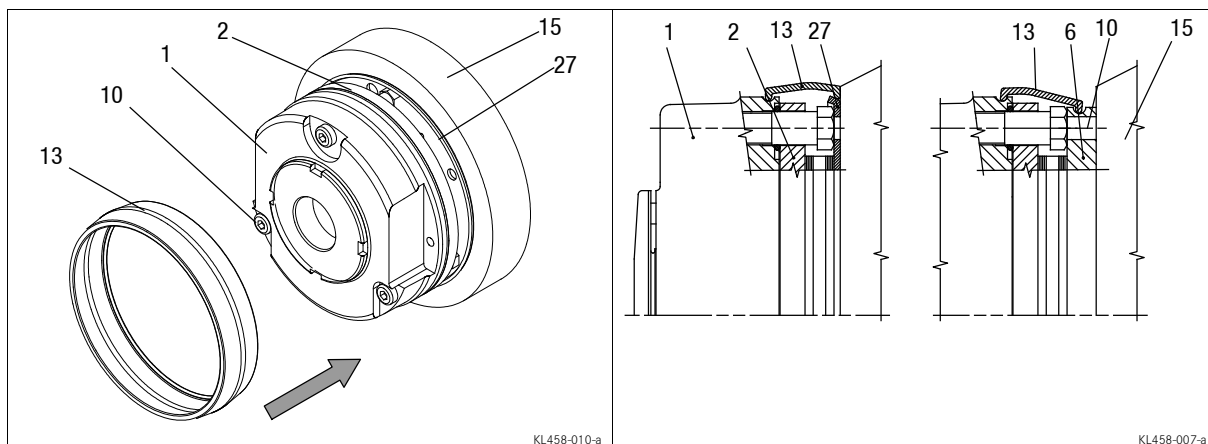

Fig. 12 Assembly of the cover seal

1	Complete stator	10	Allen screw	15	Endshield
2	Armature plate	13	Cover seal	27	Friction plate
6	Flange				

1. Insert the cable through the cover ring.
2. Push the cover ring over the stator.
3. Press the lips of the cover ring into the groove of rotor and flange.
 - If a friction plate is used, the lip must be pulled over the flanged edge.

4 Mechanical installation

4.5.6 Retrofitting of the manual release

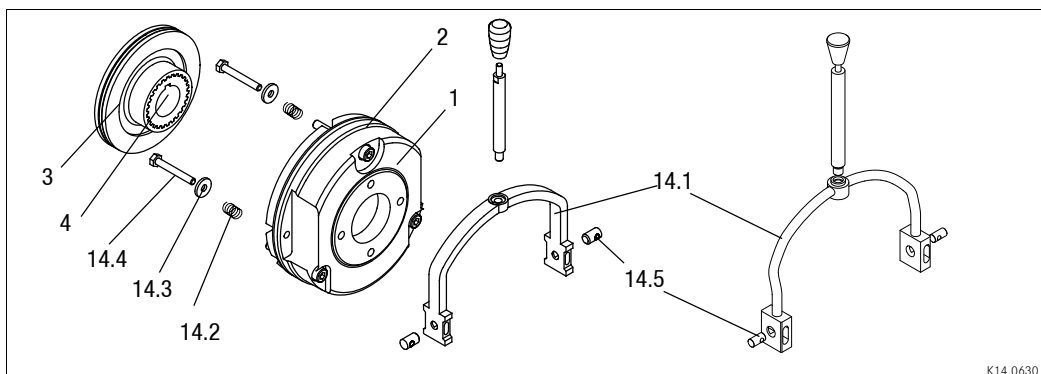

Fig. 13 Assembly of the manual release BFK458

1. Insert the compression springs (14.2) into the bore holes of the armature plate (2).
2. Push the bolts (14.5) into the bore holes of the shackle (6.1).
3. Push the hexagon head cap screw (14.4) through the compression spring (6.2) in the armature plate (2) and the bore hole in the stator (1).
4. Screw the hexagon head cap screw (14.4) into the bolts (14.5) in the shackle (14.1).
5. Tighten hexagon screw (14.4) until armature plate (1) moves towards stator (7).
6. Remove the clips (7) (throw away).
7. Adjust gap "s" and "s_L" using the hexagon head cap screw (14.4), (values for "s" and "s_L" see Tab. 7).

Type	s _L (mm)	s + ^{0.1} (mm)	s + s _L (mm)
BFK458-06	0.2	1	1.2
BFK458-08			
BFK458-10			
BFK458-12	0.3	1.5	1.8
BFK458-14			
BFK458-16			
BFK458-18	0.4	2	2.4
BFK458-20			
BFK458-25	0.5	2.5	3

Tab. 7 Adjustment setting for manual release



Stop!

Dimension "s" must be observed! Check air gap "s_L".

5 Electrical installation

5.1 Electrical connection

5.1.1 Important notes



Stop!

- If emergency switching off is carried out without the required suppressor circuit, the control unit may be destroyed.
- Observe the correct polarity of the suppressor circuit!



Danger!

- Electrical connection must only be carried out by skilled personnel!
- Connections must only be made when the equipment is de-energised! Danger through unintended starts or electric shocks.



Stop!

- It must be ensured that the supply voltage corresponds to the nameplate data.
- Voltages must be adapted to the local environment!



Tip!

Compare the coil voltage of the stator to the DC voltage of the installed rectifier.

5.1.2 Circuit proposals

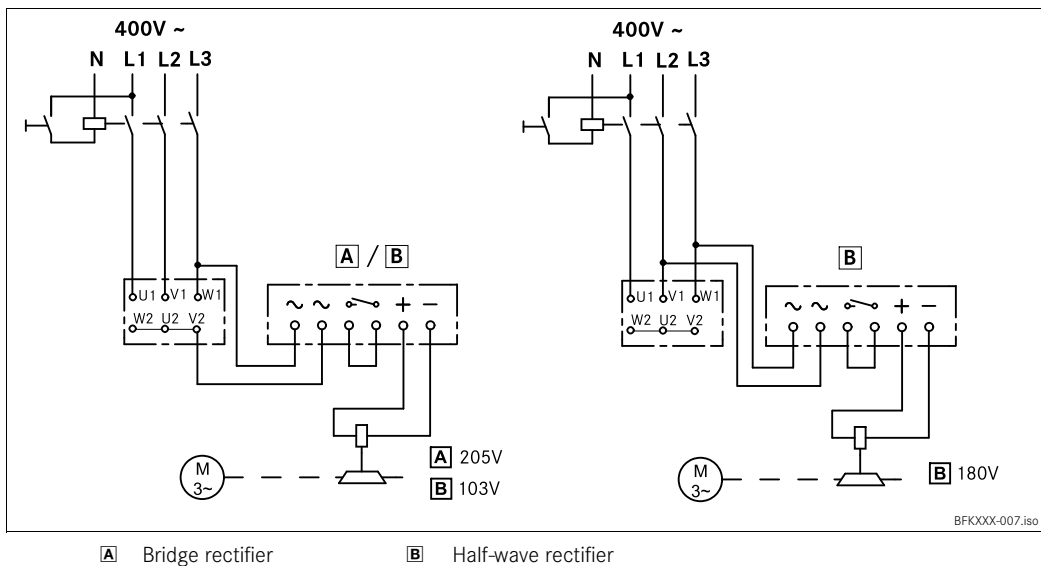

Fig. 14 Delayed engagement

5 Electrical installation

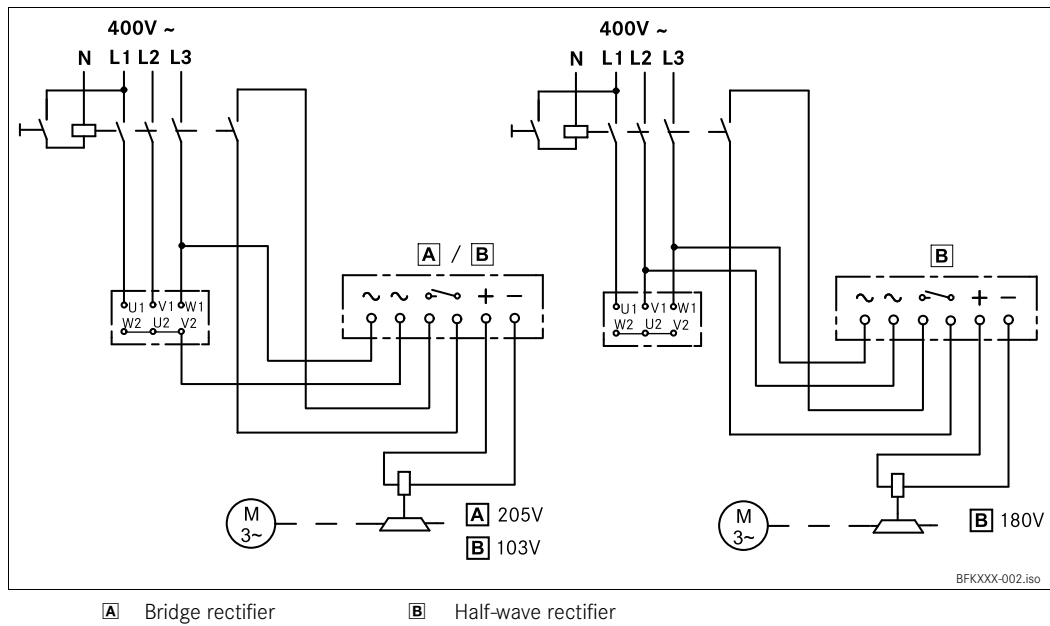

Fig. 15 Fast engagement

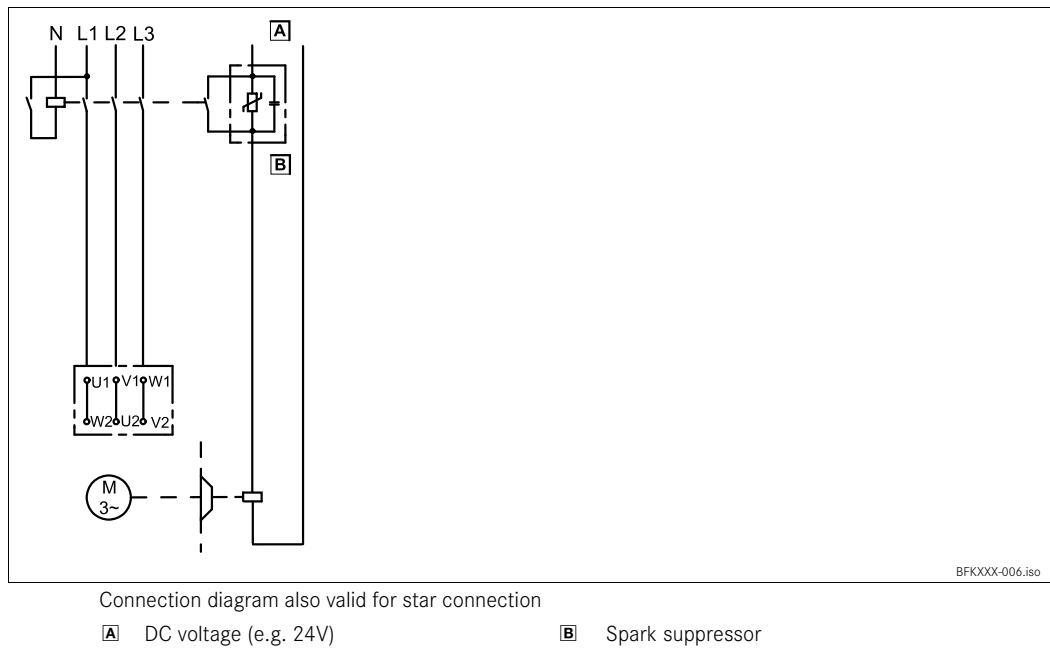

Fig. 16 Separated DC voltage (fast engagement)



Stop!

For switching on the DC side the brake must be operated with a spark suppressor to avoid impermissible overvoltages.

5 Electrical installation

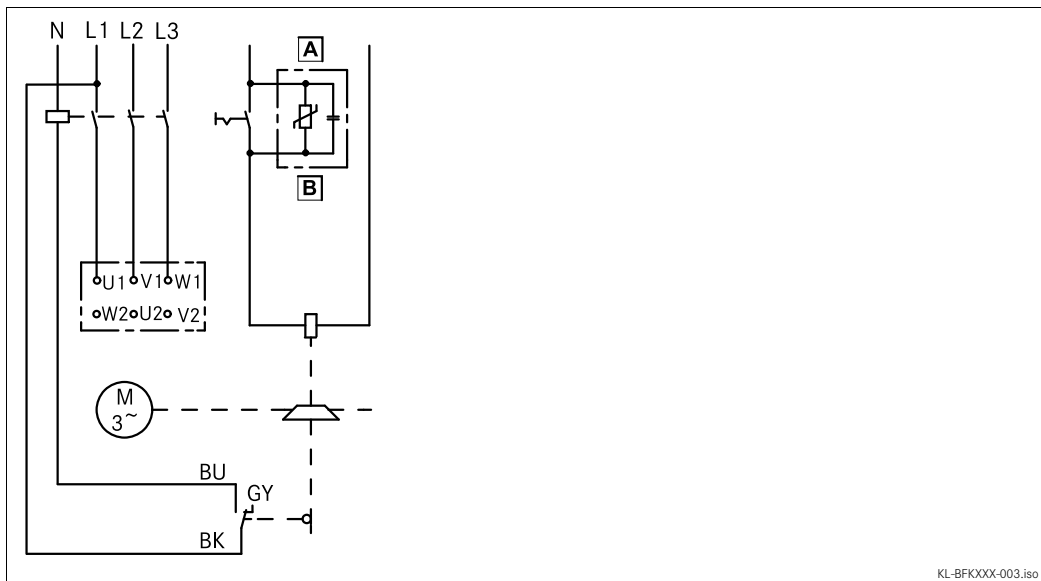

Fig. 17 With microswitch (release check); connection diagram also valid for star connection

- A DC voltage depending on coil voltage
- B Spark suppressor

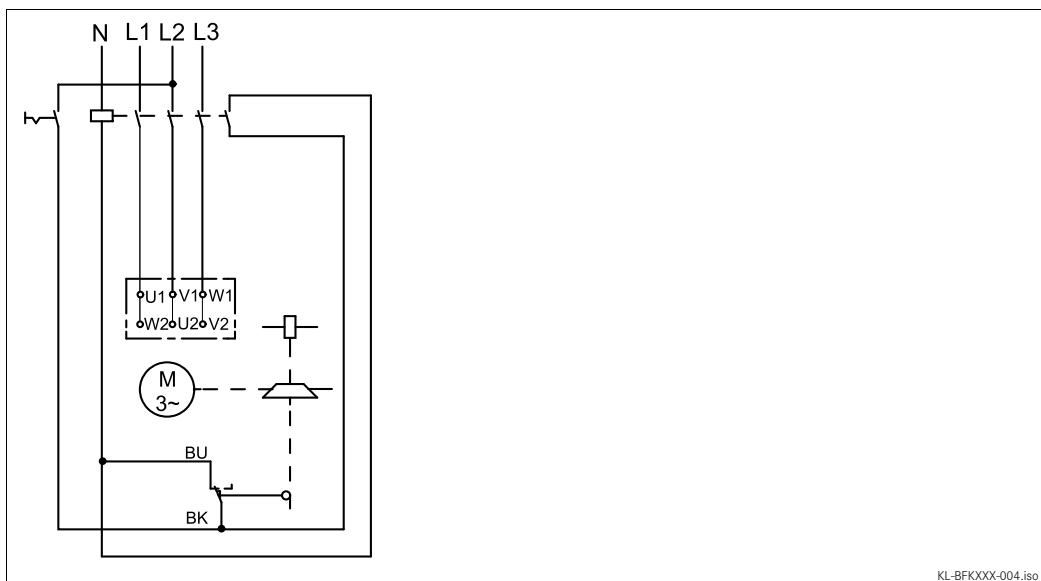

Fig. 18 With microswitch / wear check addition for all circuits; connection diagram also valid for star connection

5 Electrical installation



Tip!

During operation according to Fig. 18 the air gap is only monitored when no voltage is applied to the brake. This makes sense because it is possible that when the current flows only one side of the armature plate is attracted at first. This misalignment may cause a simulation of the maximum air gap and the actuation of the microswitch. If there is no closed contact in parallel to the microswitch contact, motor and brake will be switched off. The microswitch contact is closed again when the armature plate is completely released - the release is repeated again - because of the small difference-contact travel of the microswitch.

To avoid this misinterpretation of the microswitch signal, the signal should only be processed when no voltage is applied to the brake.

1. Mount the rectifier in the terminal box. With motors of the insulation class "H", mount the rectifier in the control cabinet. Permissible ambient temperature for the rectifier -25 °C to +70 °C.
2. Compare the coil voltage of the stator to the DC voltage of the rectifier installed.
Conversion of supply voltage to DC voltage:
 - Bridge rectifier: $U_{DC} = U_{AC} \cdot 0.9$
 - Half-wave rectifier: $U_{DC} = U_{AC} \cdot 0.45$
 - Permissible deviation of U_{coil} and U_{DC} up to $\pm 10\%$.
3. Select suitable circuit diagram ( 35).



Note!

Selection of the rectifier at voltages ≥ 460 V AC  catalogue "Electronic switchgear and accessories" Chapter spark suppressors and rectifiers.

4. Motor and brake must be wired according to the requirements of the engagement time.

5.2 Bridge/half-wave rectifiers (option)

BEG-56 1-□□□-□□□

Bridge/half-wave rectifiers are used for the supply of electromagnetic spring-applied DC brakes which have been released for operation with such rectifiers. Any other use is only permitted with the explicit written approval of INTORQ.

Once a set overexcitation time has elapsed, the bridge/half-wave rectifiers switch over from bridge rectification to half-wave rectification.

Terminals 3 and 4 are located in the DC circuit of the brake. The induction voltage peak for DC switching (see "DC switching - fast engagement" circuit diagram) is limited by an integrated overvoltage protection at terminals 5 and 6.

5 Electrical installation

5.2.1 Assignment: Bridge/half-wave rectifier - brake size

Rectifier type	AC voltage [V AC]	Overexcitation		Holding current reduction	
		Coil voltage [V DC]	Size	Coil voltage [V DC]	Size
BEG-561-255-030	230	103	06 ... 16	205	06 ... 14
BEG-561-255-130			—		16
BEG-561-440-030-1	400	180	06 ... 16	—	—

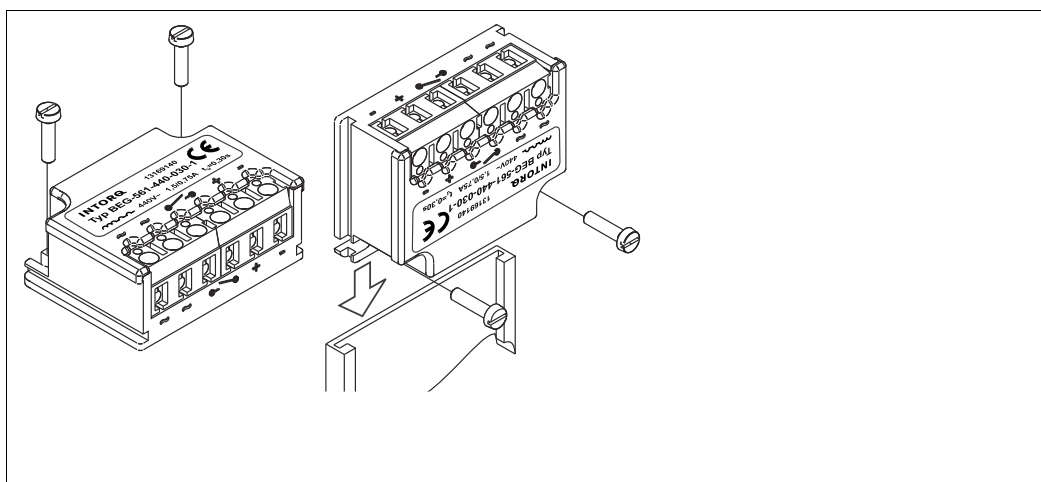

Fig. 19 BEG-561 attachment features

5.2.2 Technical data

Rectifier type	Bridge/half-wave rectifier
Output voltage for bridge rectification	$0.9 \times U_1$
Output voltage for half-wave rectification	$0.45 \times U_1$
Ambient temperature (storage/operation) [°C]	-25 ... +70

Type	Input voltage U_1 (40 Hz ... 60 Hz)			Max. current I_{max}		Overexcitation time t_{ue} (±20%)		
	min. [V ~]	rated [V ~]	max. [V ~]	bridge [A]	half-wave [A]	with U_{1min} [s]	with U_1 rated [s]	with U_1 max [s]
BEG-561-255-030	160	230	255	3.0	1.5	0.430	0.300	0.270
BEG-561-255-130						1.870	1.300	1.170
BEG-561-440-030-1	230	400	440	1.5	0.75	0.500	0.300	0.270
BEG-561-440-130				3.0	1.5	2.300	1.300	1.200

Input voltage U_1 (40 ... 60 Hz)

Tab. 8 Data for bridge/half-wave rectifier type BEG-561

5 Electrical installation

5.2.3 Reduced switch-off times

When switching on the DC side (fast engagement), switching on the AC side is also required! Otherwise, there will be no overexcitation during power-on.

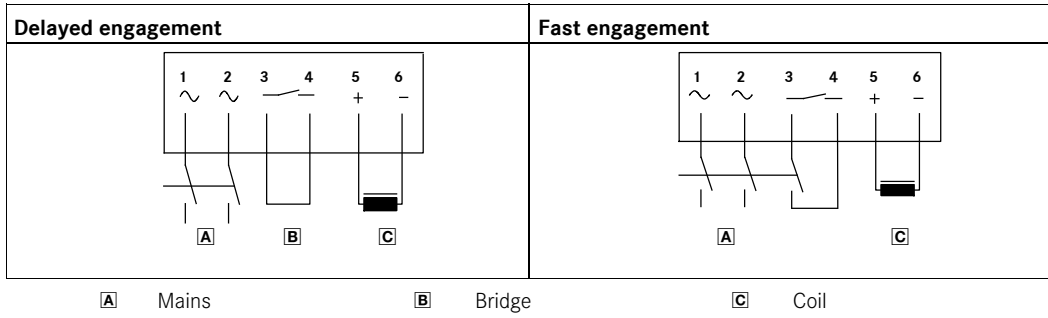

5.2.4 Permissible current load - ambient temperature

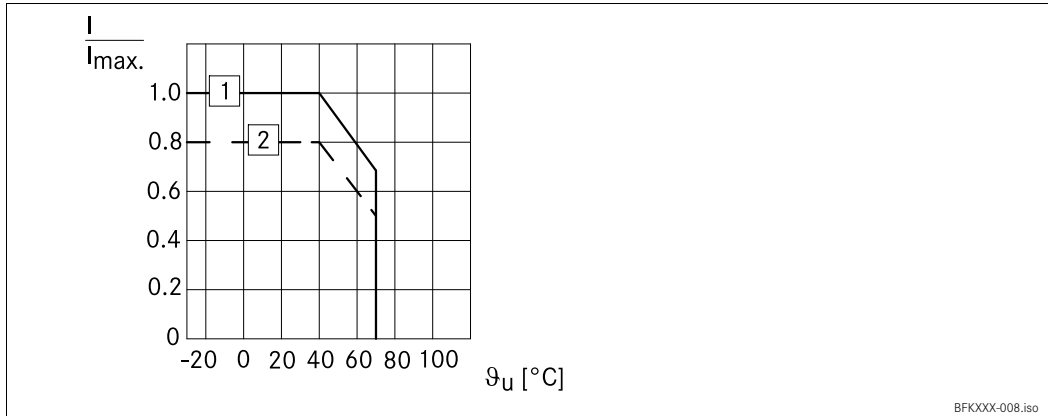

- 1 For screw assembly with metal surface (good heat dissipation)
- 2 For other assembly (e.g. glue)

6 Commissioning and operation

6.1 Important notes



Danger!

The brake must be free of residual torque.
The drive must not be running when checking the brake.



Danger!

Live connections must not be touched.

- The brakes are dimensioned in such a way that the given characteristic torques are reached safely after a short run-in process.
- Due to the fluctuating properties of the organic friction linings used and the alternating environmental conditions, deviations of the given braking torques may occur. These must be considered by corresponding safety measures in the dimensioning process. Especially with humidity and alternating temperatures, an increased breakaway torque may occur after a long downtime.
- If the brake is used as a pure holding brake without dynamic load, the friction lining must be reactivated regularly.

6.2 Function checks before commissioning

6.2.1 Operational check

Brake without microswitch



Danger!

The brake must be free of residual torque. The motor must not rotate.

In the event of failures, refer to the troubleshooting table,  56. If the fault cannot be eliminated, please contact the aftersales service.

6.2.2 Release / voltage check

For brakes without microswitch only



Danger!

The brake must be free of residual torque. The motor must not rotate.

6 Commissioning and operation



Danger!

Live connections must not be touched.

1. Remove two bridges from the motor terminals. Do **not** switch off the DC brake supply. When connecting the rectifier to the neutral point of the motor, the PE conductor must **also** be connected to this point.
2. Connect the mains supply.
3. Measure the DC voltage at the brake.
 - Compare the DC voltage measured with the voltage specified on the nameplate. A 10 % deviation is permissible.
4. Check air gap "s_L". It must be zero and the rotor must rotate freely.
5. Switch off the current.
6. Bolt bridges to the motor terminals. Remove additional PEN conductor.

Brake with microswitch



Danger!

The brake must be free of residual torque. The motor must not rotate.



Danger!

Live connections must not be touched.

1. The switching contact for the brake must be open.
2. Remove two bridges from the motor terminals to deenergise the motor.
 - Do not switch off the DC brake supply.
 - When connecting the rectifier to the neutral point of the motor, the PE conductor must also be connected to this point.
3. Apply DC voltage to the brake.
4. Measure the AC voltage at the motor terminals. It must be zero.
5. Close the switching contact for the brake.
 - The brake is released.
6. Measure the DC voltage at the brake:
 - Compare the DC voltage measured with the voltage specified on the nameplate. A ±10 % deviation is permissible.
7. Check air gap "s_L".
 - It must be zero and the rotor must rotate freely.

6 Commissioning and operation

6.2.3 Microswitch - wear check





Danger!

The brake must be free of residual torque. The motor must not rotate.



Danger!

Live connections must not be touched.

1. Remove two bridges from the motor terminals. Do not switch off the DC voltage for the brake. When connecting the rectifier to the neutral point of the motor, the PE conductor must also be connected to this point.
2. Set air gap to "s_{Lmax}". Description  28 worksteps 8-11.
3. Connect the mains supply.
4. Measure the AC voltage at the motor terminals and the DC voltage at the brake. Both must be zero.
5. Switch off the current.
6. Set air gap to "s_{LN}". Description  28 worksteps 8-11.
7. Connect the mains supply.
8. Measure the AC voltage at the motor terminals. It must be the same as the mains voltage.
9. Measure the DC voltage at the brake.
 - The DC voltage measured after the overexcitation time (see bridge/half-wave rectifier) must be half the voltage indicated on the nameplate. A 10 % deviation is permissible.
10. Check air gap "s_L". It must be zero and the rotor must rotate freely.
11. Switch off the current for the brake.
12. Bolt bridges to the motor terminals. Remove additional PEN conductor.

6 Commissioning and operation

6.2.4 Checking the manual release function



Stop!

This operational test is to be carried out additionally!



Danger!

The drive system must be load-free. The motor must not rotate.

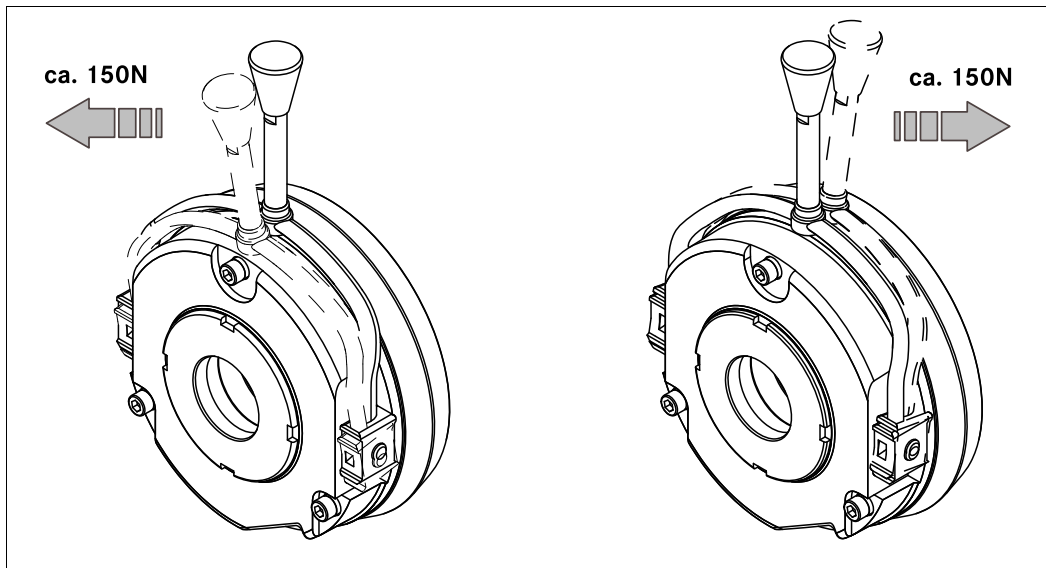

Fig. 20 Operating direction of lever

1. Motor and brake de-energised.
2. Pull the lever (Fig. 20) until the resistance increases strongly.
 - The rotor must rotate freely. A small residual torque is permissible.



Stop!

Additional tools to facilitate brake release are not allowed! (e.g. extension piece)

3. Release the lever.
 - Torque must be available!

The preparations for commissioning are completed.

In the event of failures, refer to the troubleshooting table, 56. If the fault cannot be eliminated, please contact the aftersales service.

6 Commissioning and operation

6.3 Commissioning

1. Switch on drive system.
2. Carry out a braking test, if necessary, reduce brake torque.

6.4 During operation

**Danger!**

The running rotor must not be touched.

**Danger!**

Live connections must not be touched.

- Check the brake regularly during operation. Take special care of:
 - unusual noises or temperatures
 - loose fixing elements
 - the condition of the electrical cables.
- The armature plate must be attracted and the drive must move without residual torque.
- Measure the DC voltage at the brake.
 - Compare the DC voltage measured with the voltage specified on the nameplate. A $\pm 10\%$ deviation is permissible.

6 Commissioning and operation

6.4.1 Brake torque reduction

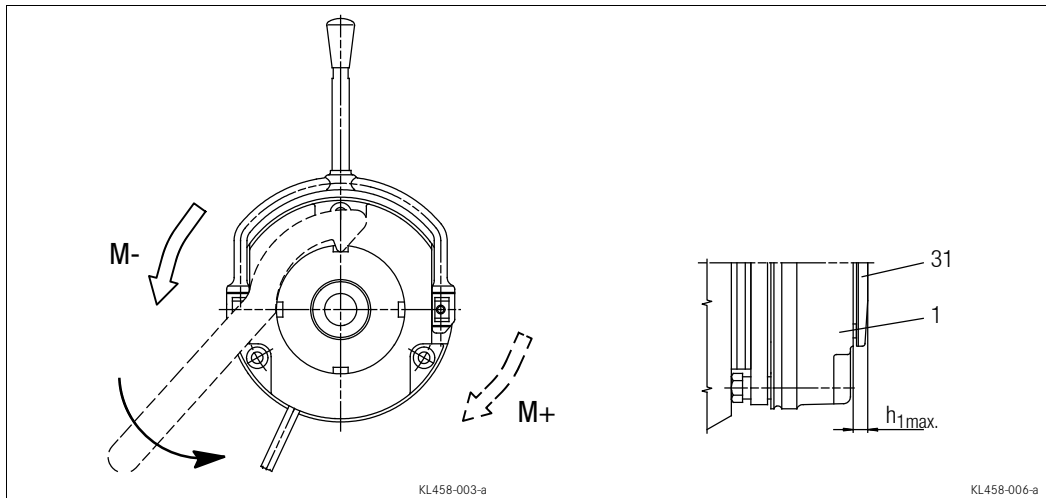

Fig. 21 Reducing the brake torque

1 Complete stator 31 Adjuster nut

1. Turn the adjuster nut (31) counterclockwise using the hook wrench.
 - Observe the notches. Positions between notches are impermissible. (Values for the brake torque reduction see chapter 3.2.1).
 - The maximum permissible projection " $h_{E_{max}}$ " of the adjuster nut (8) to the stator (1) is to be observed (values for " $h_{E_{max}}$ " see chapter 3.2).



Danger!

The reduction of the brake torque does not increase the maximum permissible air gap " $s_{L_{max}}$ ".

Do not change the manual release setting for models with manual release.

7 Maintenance/repair

7.1 Wear of spring-applied brakes

The following table describes the different causes of wear and their effects on the components of the spring-applied brake. The important influencing factors must be quantified so that the service life of the rotor and brake can be calculated and that the maintenance intervals to be prescribed can be specified precisely. The most important factors in this context are the applied friction energy, the initial speed of braking and the operating frequency. If several of the causes of friction lining wear occur in an application at the same time, the influencing factors are to be added together when the amount of wear is calculated.

Component	Cause	Effect	Influencing factors
Friction lining	Braking during operation	Wear of friction lining	Friction work
	Emergency stops		
	Overlapping wear during start and stop of drive		Number of start/stop cycles
	Active braking via the drive motor with support of brake (quick stop)		
	Starting wear in case of motor mounting position with vertical shaft, even when the brake is not applied		
Armature plate and counter friction face	Rubbing of brake lining	Run-in of armature plate and counter friction face	Friction work
Splining of brake rotor	Relative movements and shocks between brake rotor and brake shaft	Wear of splining (primarily on the rotor side)	Number of start/stop cycles
Brake support	Load alternation and jerks in the backlash between armature plate, sleeve bolts and guide bolt	Breaking of armature plate, sleeve bolts and guide bolt	Number of start/stop cycles, braking torque
Springs	Axial load cycle and shear stress of springs through radial backlash on reversal of armature plate	Reduced spring force or fatigue failure	Number of switching operations of brake

Tab. 9 Causes for wear

7 Maintenance/repair

7.2 Inspections

To ensure safe and trouble-free operation, spring-applied brakes must be checked and maintained at regular intervals. Servicing can be made easier if good accessibility of the brakes is provided in the plant. This must be considered when installing the drives in the plant.

Primarily, the necessary maintenance intervals for industrial brakes result from the load during operation. When calculating the maintenance interval, all causes for wear must be taken into account, (☞ 47). For brakes with low loads such as holding brakes with emergency stop, we recommend a regular inspection at a fixed time interval. To reduce the cost, the inspection can be carried out along with other regular maintenance work in the plant if necessary.

If the brakes are not maintained, failures, production losses or damage to the system may occur. Therefore, a maintenance concept adapted to the particular operating conditions and brake loads must be defined for every application. For the spring-applied brakes, the maintenance intervals and maintenance operations listed in the below table must be provided. The maintenance operations must be carried out as described in the detailed descriptions.

7.2.1 Maintenance intervals

Designs	Service brake	Holding brake with emergency stop
BFK458-□□ E / N BFK458-□□ L	<ul style="list-style-type: none"> ■ according to service life calculation ■ otherwise every six months ■ after 4000 operating hours at the latest 	<ul style="list-style-type: none"> ■ at least every 2 years ■ after 1 million cycles at the latest ■ provide shorter intervals with frequent emergency stops

7.3 Maintenance



Note!

Brakes with defective armature plates, springs or flanges must completely be replaced.

In general, the following must be observed when carrying out any inspection or maintenance work:

- Remove impurities through oil and grease using brake cleaning agents, if necessary, replace brake after identifying the cause of the contamination. Dirt deposits in the air gap between stator and armature plate impair the function of the brake and must be removed.
- After the replacement of the rotor, the initial braking torque will not be reached until the friction surfaces are run in. After the replacement of the rotor, the run-in armature plates and flanges have a higher initial rate of wear. In this case, the air gap must be adjusted betimes if necessary.

7 Maintenance/repair

7.3.1 Checking the component parts

With assembled brake	<ul style="list-style-type: none"> ■ Check function of ventilation and control ■ Measure the air gap (adjust if necessary) ■ Measure the rotor thickness (replace rotor if necessary) ■ Thermal damage to armature plate or flange (dark blue tarnishing) 	<ul style="list-style-type: none"> 📖 50 📖 50 📖 49
After removing the brake	<ul style="list-style-type: none"> ■ Check clearance of the rotor gearing (replace worn-out rotors) ■ Wear of the torque bearing on threaded sleeves, dowel pins and armature plate ■ Checking springs for damage ■ Checking armature plate and flange/endshield ■ Evenness size 06...12 < 0.06 mm ■ Evenness from size 14 on < 0.1 mm ■ max. run-in depth = rated air gap of brake size 	<ul style="list-style-type: none"> 📖 51

7.3.2 Checking the rotor thickness



Danger!

When the rotor thickness is checked, the motor must not run.

1. Remove fan cover and cover ring if attached.
2. Measure rotor thickness with calliper gauge. If a friction plate is attached, ensure a flanged edge at the outer diameter of the friction plate.
3. Compare measured rotor thickness with minimally permissible rotor thickness (values 📖 15).
4. If required, exchange the entire rotor. Description 📖 51.

7.3.3 Checking the air gap



Danger!

The motor must not be running when checking the air gap.

1. Check the air gap "s_L" near the fixing screws between the armature plate and stator using a feeler gauge (📖 15).
2. Compare air gap measured to maximally permissible air gap "s_{L max.}" (📖 15).
3. If required, set air gap to "s_{LN}" (📖 50).

7 Maintenance/repair

7.3.4 Release / voltage



Danger!

The running rotor must not be touched.



Danger!

Live connections must not be touched.

1. Observe the brake function during operation of the drive. The armature plate must be attracted and the rotor must move without residual torque.
2. Measure the DC voltage at the brake.
 - The DC voltage measured after the overexcitation time (see bridge/half-wave rectifier) must be half the voltage indicated on the nameplate. A 10 % deviation is permissible.

7.3.5 Adjusting the air gap



Danger!

The brake must be free of residual torque.



Stop!

Please observe when mounting the flange with additional screws:

Behind the threaded holes for the screws in the flange there must be clearing holes in the endshield. Without clearing holes the minimum rotor thickness cannot be used. Under no circumstances may the screws be pressed against the endshield.

1. Unbolt screws (Fig. 9).
2. Screw the threaded sleeves into the stator by using a spanner. $\frac{1}{6}$ revolution reduces the air gap by approx. 0.15 mm.
3. Tighten screws, torques 15.
4. Check air gap "s_L" near the screws using a feeler gauge, "s_{LN}" 15.
5. If the difference between the measured air gap and "s_{LN}" is too large, repeat the readjustment.

7 Maintenance/repair

7.3.6 Rotor replacement





Danger!

The brake must be free of residual torque.

1. Switch off voltage!
2. Disconnect the supply cable.
3. Loosen the screws evenly and remove them completely.
4. Remove the complete stator from the end shield. Observe the supply cable.
5. Pull the complete rotor off the hub.
6. Check hub teeth.
7. Replace the hub as well if worn.
8. Check the friction surface at the end shield. In case of strong scoring at the flange, replace the flange. If scoring occurs at the end shield, re-finish end shield.
9. Measure rotor thickness (new rotor) and sleeve bolt head with a caliper gauge.
10. Calculate the gap between the stator and the armature plate as follows:

$$\text{Gap} = \text{rotor thickness} + s_{LN} - \text{head height}$$

("s_{LN}"  15)

11. Unscrew the sleeve bolts evenly until the calculated gap between stator and armature plate is reached.
12. Install and adjust new rotor and stator,  28.
13. Reconnect the supply cable.

7 Maintenance/repair

7.4 Spare-parts list

- Only parts with item numbers are available.
 - The item numbers are only valid for the standard design.
- Please include the following information with the order:
 - Order number of the brake
 - Position number of the spare part

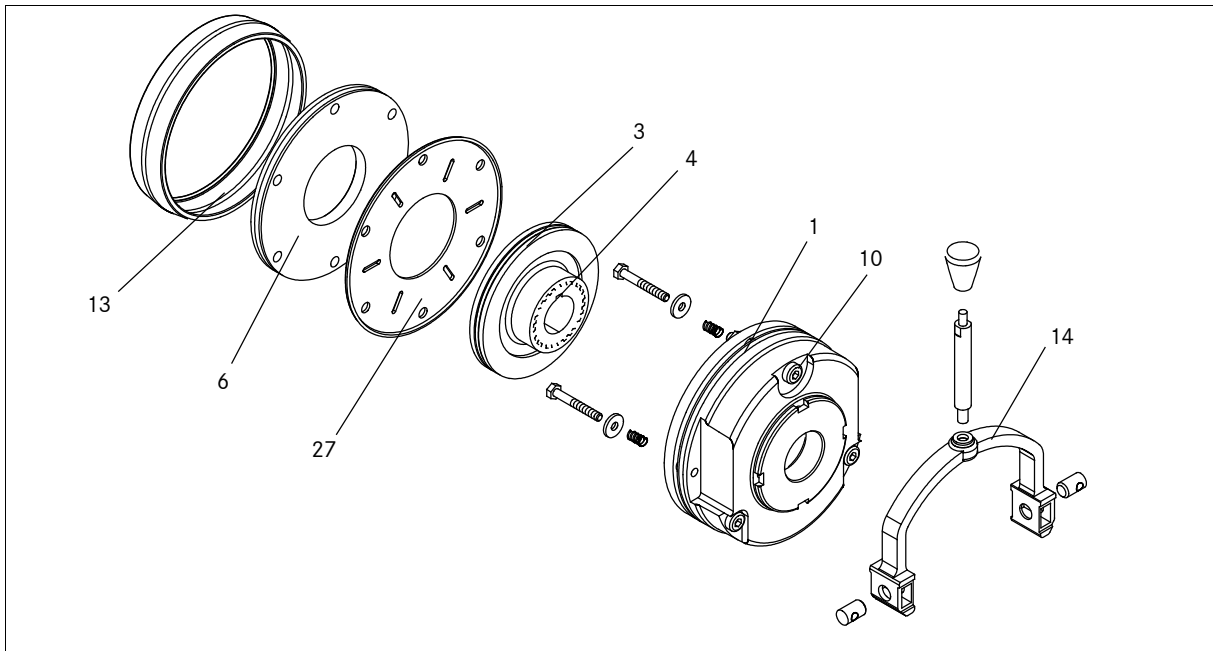

Fig. 22 Spring-applied brake INTORQ BFK458-06 to 25

Pos.	Designation	Variant
1	Complete stator, module E Complete stator, module N	Voltage / brake torque
3	Complete rotor Complete rotor, low-noise version	
4	Hub	Bore
6	Flange Hartchromed flange	
10	Set of fastening screws Allen screw DIN912 8.8	for mounting to the motor / flange Friction plate: for flange with through hole for connection flange / double brake
14	Manual release	
13	Cover seal	
27	Friction plate	
	Terminal box as mounting kit	
	Speedometer flange	
	Connection flange for double brake	
	Brake cover (degree of protection corresponds to IP65)	

7 Maintenance/repair

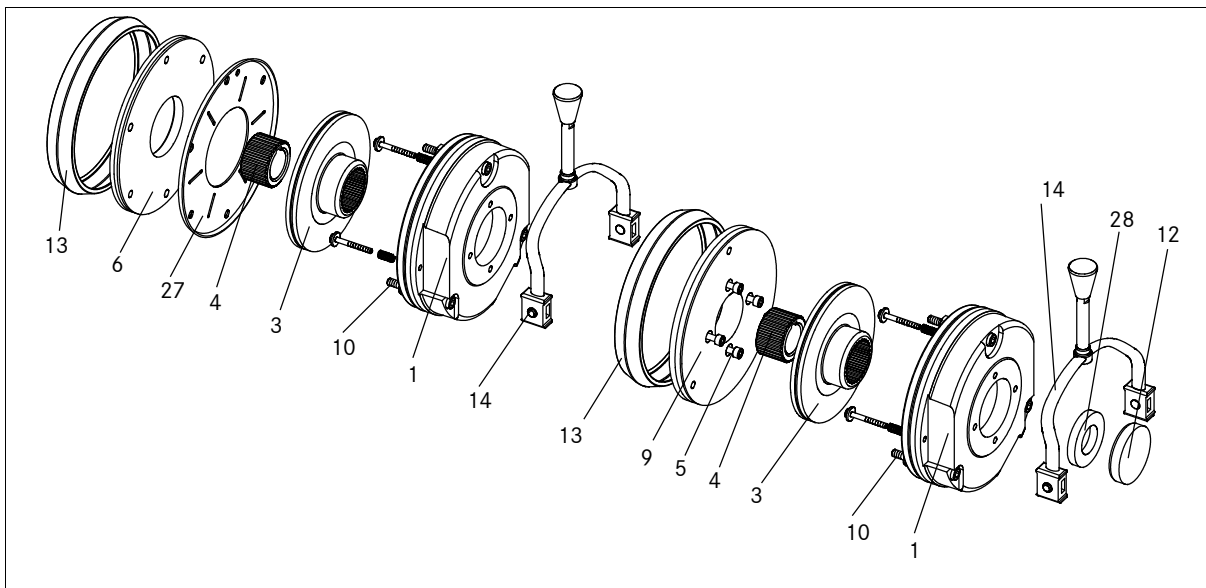

Fig. 23 Double spring-operated brake INTORQ BFK458-06 to 25

Pos.	Designation	Variant
1	Complete stator, module N	Voltage / brake torque - as option with noise-reduced armature plate
3	Complete rotor	Aluminium rotor Aluminium rotor with sleeve - Low-noise version
4	Hub with standard bore	Hole diameter [mm] slot according to DIN 6885/1
5	Set of fastening screws; Allen screw DIN912 8.8	for connection flange / double brake
6	Flange Hartchromed flange	
9	Connection flange for double brake	
10	Set of fastening screws; Allen screw DIN912 8.8	■ for mounting to the flange ■ for mounting to the motor / friction plate ■ for flange with through hole
12	Cap	Basic module N
13	Cover seal	
14	Manual release with standard lever	Mounting kit
27	Friction plate	
28	Shaft seal	Shaft diameter on request

7 Maintenance/repair

7.5 Spare parts order

INTORQ BFK458-□□□ / complete stator

- Size** 06 08 10 12 14
 16 18 20 25
- Design** E (with adjuster nut) N (without adjuster nut)
- Voltage** 24 V 96 V 103 V 170 V 180 V
 190 V 205 V
- Braking torque** _____ Nm (see torque ranges)
- Cable length** Standard
 _____ mm (from 100 mm to 1000 mm in 100 mm steps,
 from 1000 mm - 2500 mm in 250 mm steps)
- Manual release** mounted
- Armature plate** Standard with washer/brass foil
 noise-reduced (O-ring version) hartchromed
- Microswitch** Monitoring of the switching function (from size 12 on)
 Wear monitoring (from size 12 on)
- Terminal box** mounted (from size 12 on)

Accessories

- Rotor** Aluminium Low-noise version (rotor with sleeve)

 Plastic (only size 06/08)
- Hub** _____ mm (for bore diameter, see dimensions)
- Set of fixing screws** for mounting to the flange
 for mounting to the motor / friction plate
 for flange with through holes (up to and including size 16)
 for connection flange / double brake
- Manual release** as mounting kit
- Terminal box** as mounting kit
- Flange** Friction plate (up to and including size 16)
 Flange
 Speedometer flange
 Connection flange / double brake
- Sealing** Cover seal
 Shaft seal (shaft diameter on request)
 Cap
 Brake cover

7 Maintenance/repair

Electrical accessories



Rectifier type	AC voltage [V AC]	Overexcitation		Holding current reduction	
		Coil voltage [V DC]	Size	Coil voltage [V DC]	Size
BEG-561-255-030	230	103	06 ... 16	205	06 ... 14
BEG-561-255-130			—		16
BEG-561-440-030-1	400	180	06 ... 16	—	—

8 Troubleshooting and fault elimination

If any malfunctions should occur during operation, please check the possible causes using the following table. If the fault cannot be eliminated by one of the listed measures, please contact the aftersales service.

Fault	Cause	Remedy
Brake cannot be released, air gap is not zero	Coil is interrupted	<ul style="list-style-type: none"> ■ Measure coil resistance using multimeter: <ul style="list-style-type: none"> - If the resistance is too high replace the stator.
	Coil has interturn fault or short circuit to ground	<ul style="list-style-type: none"> ■ Measure coil resistance using multimeter: <ul style="list-style-type: none"> - Compare measured resistance to rated resistance. For values, ≈ 15. If the resistance is too low, replace the entire stator. ■ Test the coil for short circuit to ground using a multimeter: <ul style="list-style-type: none"> - If a short circuit to ground occurs, replace the stator. ■ Check the brake voltage (see defective rectifier, voltage too low).
	Defective or wrong wiring	<ul style="list-style-type: none"> ■ Check and correct wiring. ■ Check the cable using a multimeter: <ul style="list-style-type: none"> - Replace defective cable
	Defective or wrong rectifier	<ul style="list-style-type: none"> ■ Measure the DC voltage at the rectifier using a multimeter. When the DC voltage is zero: <ul style="list-style-type: none"> ■ Measure the AC voltage at the rectifier. When the AC voltage is zero: <ul style="list-style-type: none"> - Apply voltage - Check fuse - Check wiring When the AC voltage is ok: <ul style="list-style-type: none"> - Check rectifier - Replace defective rectifier When the DC voltage is too low: <ul style="list-style-type: none"> - Check rectifier - If diode is defective, use suitable new rectifier ■ Check the coil for fault between turns and short circuit to ground. ■ If the rectifier defect occurs again, replace the entire stator, even if you cannot find any fault between turns or short circuit to ground. The fault may occur later during heating-up.
	Incorrect wiring of microswitch	Check the wiring of the microswitch and correct it.
	Incorrect setting of microswitch	Replace the stator and complain about the micro switch quality at the manufacturer
	Air gap too big	Readjust the air gap, ≈ 50
Rotor cannot rotate freely	Wrong setting of manual release	Check dimension $s+s_L$ with energised brake. The dimension must be identical at both sides. Correct if necessary.
	Air gap s_L too small	Check air gap $s_{L\bar{u}}$ and readjust it, if necessary ≈ 50 .

8 Troubleshooting and fault elimination

Fault	Cause	Remedy
Rotor not thick enough	Rotor has not been replaced in time	Replace rotor,  51
Voltage is not zero when checking the operation  41	Incorrect wiring of microswitch	Check the wiring of the microswitch and correct it.
	Defective microswitch or incorrect setting	Replace the stator and send the defective stator to the manufacturer.
Voltage too high	Brake voltage does not match the rectifier	Adapt rectifier and brake voltage to each other.
Voltage too low	Brake voltage does not match the rectifier	Adapt rectifier and brake voltage to each other.
	Defective rectifier diode	Replace rectifier by a suitable new one.
AC voltage is not mains voltage	Fuse missing or defective	Select a connection with proper fusing.
	Incorrect wiring of microswitch	Check the wiring of the microswitch and correct it.
	Defective microswitch or incorrect setting	Replace the entire stator and return it to the manufacturer.



Notes



Notes

 **INTORQ GmbH & Co KG**

Germany

Postfach 1103

D-31849 Aerzen

Wülmsers Weg 5

D-31855 Aerzen

 +49 5 154 70534-444

 +49 5 154 70534-200

 info@intorq.com

 **INTORQ (SHANGHAI) Co., Ltd**

China

No. 600, Xin Yuan Road

Building No. 6 / Zone B

Nan Hui District, Lingang

Shanghai, China 201306

应拓柯制动器（上海）有限公司
中国

新元南路600号6号楼1楼B座

上海 南汇 201306

 +86 21 20363-810

 +86 21 20363-805

 info@cn.intorq.com

 **INTORQ US Inc.**

USA

300 Lake Ridge Drive SE

Smyrna, GA 30082

 +1 678 309-1155

 +1 678 309-1157

 info@us.intorq.com