

**INTORQ**

setting the standard

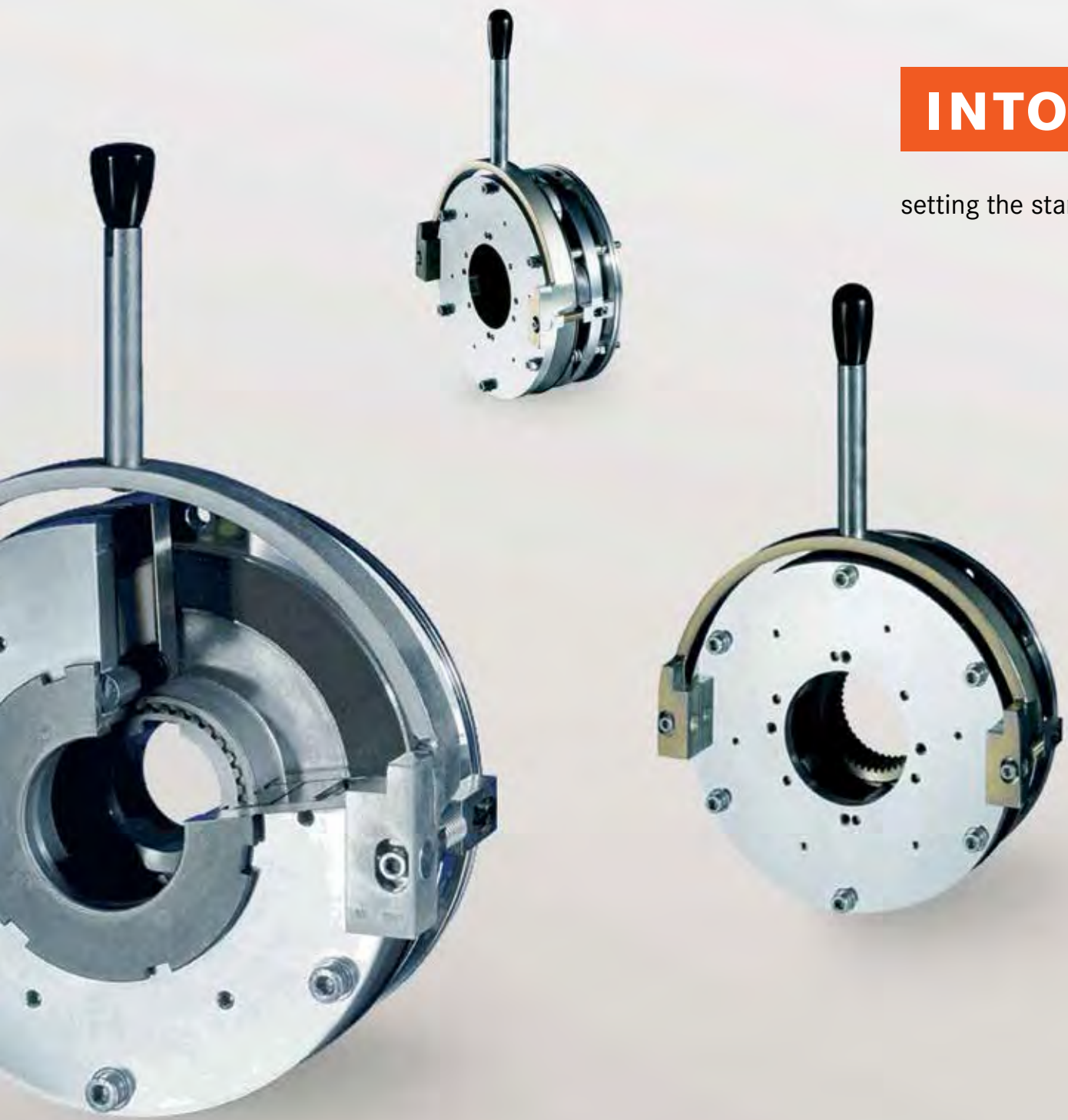

## **BFK468 spring-applied brake**

The Performance Standard

100 - 2,400 Nm

[www.intorq.de](http://www.intorq.de)

## We set the standards

The INTORQ brand stands for reliable brake solutions of the highest standard. Whether in cranes, wind turbines or lift systems – INTORQ products are used in the most diverse of applications. Rely on us to create the right solution for your drive – individually and reliably.

With its high number of variants, INTORQ's range of modular products is used in many motors and geared motors and has set standards worldwide. With the establishment of facilities in Shanghai and Atlanta, we have also consistently expanded our international presence. So wherever you are in the world, our network of sales and service staff is always close at hand to support you.



### INTORQ at a glance

- Electromagnetic brakes and clutches
- Configurable standard solutions and custom-made solutions
- Development and production centred in Aerzen
- Fast delivery times worldwide thanks to production sites in Shanghai und Atlanta
- 45 million euros a year sales volume
- 800,000 units a year
- 10,000 square metres production area
- 220 employees
- Market leader with 63 sales partners in 49 countries



## BFK468 spring-applied brake

High-power drives are achieving higher and higher motor speeds and drive torque levels. However, despite the increased performance requirements, the installation space allocated for brakes is actually getting smaller. The innovative multi-coil technology forms the basis for this performance class.

### Properties

- Up to twice the braking torque in comparison with the BFK458
- Fixed or adjustable braking torque
- Fast operating times
- Long maintenance intervals thanks to large working air gap

### Fields of application

- Brake motors
- Cranes
- Port facilities
- Stage machinery
- Storage technology
- Escalators

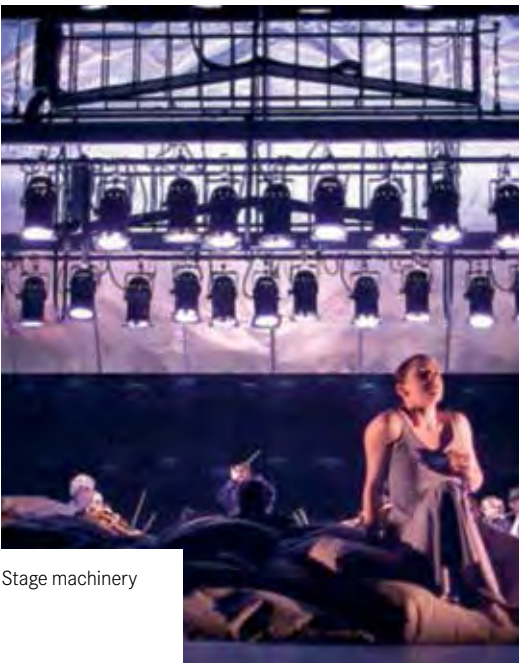

Stage machinery



Cranes

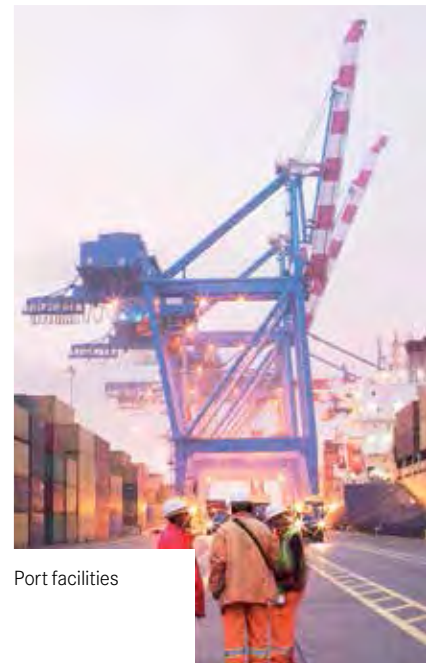

Port facilities

## INTORQ BFK468-□□□ product key

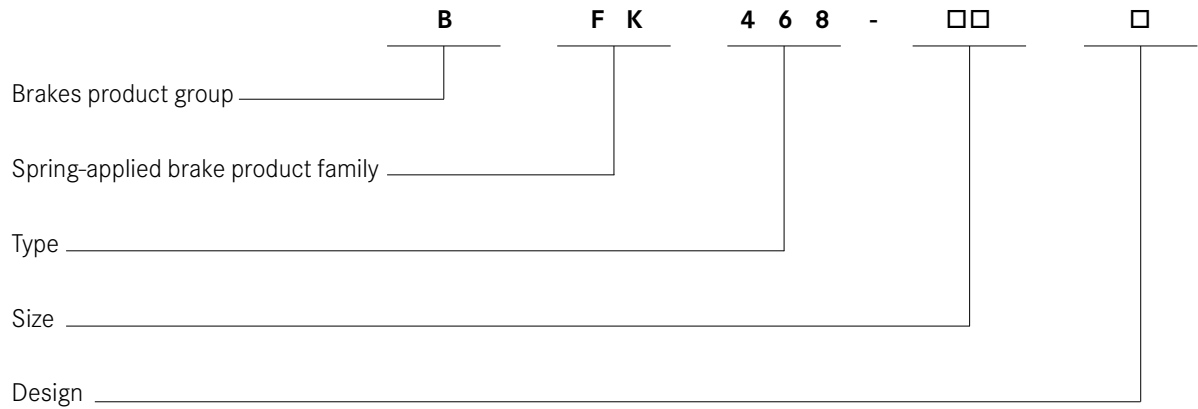

### Size

18, 20, 25, 31

### Stator design

E – Adjustable (braking torque can be reduced using torque adjustment ring)

N – not adjustable

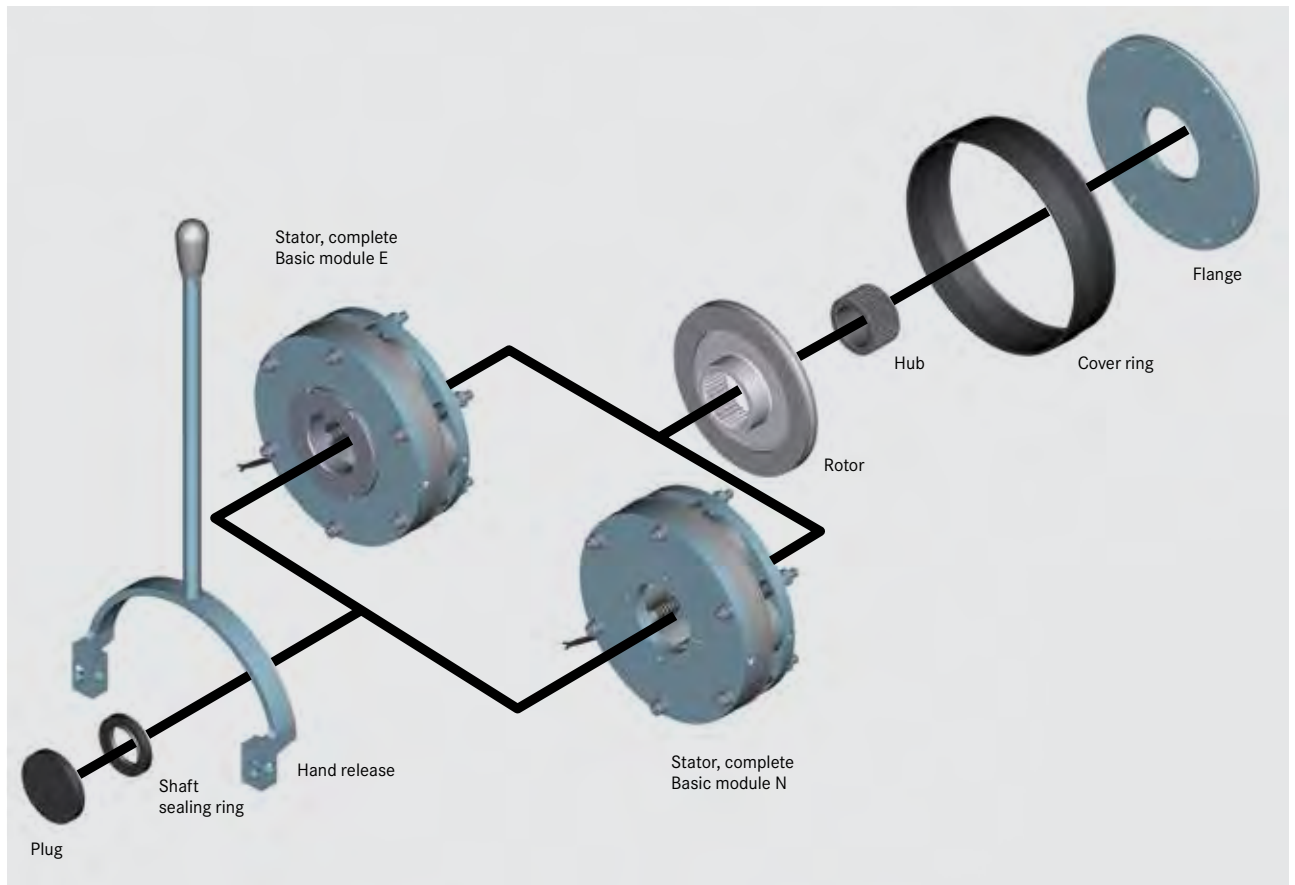

Modular system BFK468

## Product information

### A powerful and complete range

- 4 sizes
- Standard voltages 205/103 V, 360/180 V (release voltage/holding voltage)
- Torque ranges from 100 to 2,400 Nm

### Versatile

- Modular structure for virtually all applications
- Connection compatible with the BFK458 range of brakes

### Torque transmission

- Can be frictionally engaged during dry running
- Special machining of the friction surfaces ensures that the characteristic torques are already achieved after just a few switching operations
- Fixed bearing is not required on the brake

### Durable

- The insulation system in line with temperature class F (155°C) ensures that the winding has a long service life
- The brakes are designed for 100 % duty time (with holding current reduction) with an INTORQ half-wave bridge rectifier

### Quick and easy mounting

- Preset air gap

### Low maintenance

- Long rotor/hub connection with low rate of wear and tried-and-tested involute gear
- Low-wear, asbestos-free friction lining comes as standard

### Reliable

- The certified ISO 9001 and ISO 14001 quality assurance system provides the basis for consistently high-quality products
- Production and testing in accordance with VDE 0580

### Options

- Manual release for sizes 18–25, release on both sides
- Noise-reduced designs
- Various types of corrosion protection and enclosures
- Air gap or wear monitoring via microswitch

## List of abbreviations

<b>P<sub>N</sub></b>	[W]	Rated coil power at rated voltage and 20°C	<b>t<sub>1</sub></b>	[s]	Engagement time, the sum of the delay time plus the braking torque rise time
<b>U<sub>N</sub></b>	[V DC]	Rated coil voltage			
<b>M<sub>K</sub></b>	[Nm]	Rated torque of the brake at a relative speed of 100 r/min	<b>t<sub>1</sub></b>	[s]	$t_1 = t_{11} + t_{12}$
<b>Δn<sub>0</sub></b>	[r/min]	Initial relative speed of the brake	<b>t<sub>2</sub></b>	[s]	Disengagement time, time from switching the stator until the torque has reduced to 0.1 M <sub>K</sub>
<b>Q</b>	[J]	Heat/energy	<b>t<sub>3</sub></b>	[s]	Slipping time, engagement time of the brake (after t <sub>11</sub> ) to standstill
<b>Q<sub>E</sub></b>	[J]	Maximum permissible friction work per switching cycle, thermal rating of the brake	<b>t<sub>11</sub></b>	[s]	Delay time when connecting, time from disconnecting the voltage until the torque begins to rise
<b>S<sub>h</sub></b>	[1/h]	Operating frequency, the number of repeated operations per unit time	<b>t<sub>12</sub></b>	[s]	Rise time of rated torque, time from beginning of rise of torque until rated torque is reached
<b>S<sub>hmax</sub></b>	[1/h]	Maximum permissible operating frequency, depending on the friction work per operation	<b>t<sub>ue</sub></b>	[s]	Overexcitation time
<b>S<sub>hue</sub></b>	[1/h]	Transitional operating frequency, thermal rating of the brake depending on the friction work per operation			
<b>s<sub>LN</sub></b>	[mm]	Rated air gap			
<b>s<sub>HL</sub></b>	[mm]	Hand-release air gap, setting dimension of hand-release			

## Functional principle

### Basic module E + rotor + hub + flange

### Basic module N + rotor + hub + flange

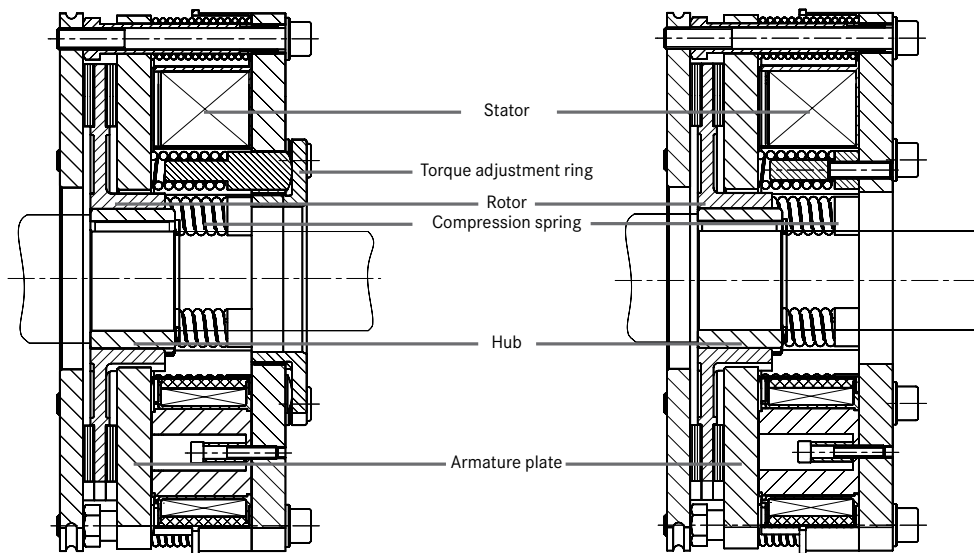

INTORQ BFK468 spring-applied brakes are single-disk brakes with two friction surfaces. When deenergised, several compression springs are used to generate the braking torque through friction locking. The brake is released electromagnetically with holding-current reduction via an INTORQ half-wave bridge rectifier. During braking, the compression springs use the armature plate to press the rotor (which can be shifted axially on the hub) against the counter friction face. When the brakes are applied, the air gap  $s_{LN}$  is present between the armature plate and the stator. A DC voltage is applied to the stator's coil to release the brake.

The resulting magnetic flux works against the spring force to draw the armature plate to the stator. This releases the rotor from the spring force and allows it to rotate freely. The DC voltage is then reduced to half by the accompanying switching device. Basic module E supports the use of the torque adjustment ring to reduce the braking torque.

# Technical data

## Characteristic torques

Basic modules E and N can be supplied in the torque ratings listed below. INTORQ brakes are designed in such a way that the stated characteristic torque levels can generally be securely achieved following a brief running-in period. However, deviations from the stated braking torques can occur due to the fluctuating properties of the organic friction linings used and changing environmental conditions. These must be taken into account by means of corresponding safety measures during the design phase. Increased breakaway torques can occur after long downtimes, particularly in humid environments or areas subject to

changes in temperature. The braking torque should always be checked when using the brake on customers' friction surfaces. If the brake is to be used purely as a holding brake without any dynamic load, the friction lining needs to be reactivated at regular intervals. On basic module E, the braking torque can be reduced using the torque adjustment ring included in the stator. However, the torque adjustment ring may only be unscrewed up to the limit  $h_{1max}$ . It is important to note that the engagement and disengagement times vary, depending on the braking torque being used.

Size	18		20		25		31
	Rated torque [Nm]	Torque reduction E per detent [Nm]	Rated torque [Nm]	Torque reduction E per detent [Nm]	Rated torque [Nm]	Torque reduction E per detent [Nm]	Rated torque [Nm]
<b>Rated torques, with reference to the relative speed <math>\Delta n = 100</math> rpm</b>  <b>Depending on the rated torque (spring configuration), the angle of rotation for the braking torque reduction on basic module E can be 60°, 120° or 180°</b>					230 N		
	100 N/E	6.4	170 N/E	19.8	260 N/E	16.5	
	115 N/E	6.4	200 N/E	19.8	300 N/E	8.2	720 N
	130 N/E	6.4	230 N/E	9.9	350 N/E	8.2	960 N
	<b>150 N/E</b>	<b>3.2</b>	<b>260 N/E</b>	<b>9.9</b>	<b>400 N/E</b>	<b>8.2</b>	<b>1,200 N</b>
	165 N/E	3.2	300 N/E	19.8	445 N/E	16.5	1,440 N
	185 N/E	6.4	345 N/E	19.8	490 N/E	8.2	1,680 N
	200 N/E	6.4	400 N/E	19.8	520 N/E	16.5	1,920 N
	235 N/E	6.4	440 N/E	19.8	600 N/E	16.5	2,160 N
	265 N/E	6.4	480 N/E	19.8	700 N/E	16.5	2,400 N
300 N/E	6.4	520 N/E	19.8	800 N/E	16.5		

■ N ... Braking torque for the N model (without torque adjustment ring)

■ E ... Braking torque for the E model (with torque adjustment ring)

□ Holding brake with emergency stop operation  
( $s_{Lmax}$  approximately  $2.0 \times s_{LN}$ )

□ Service brake  
( $s_{Lmax}$  approximately  $4.0 \times s_{LN}$ )

□ Standard braking torque

## Technical data

### Dimensions

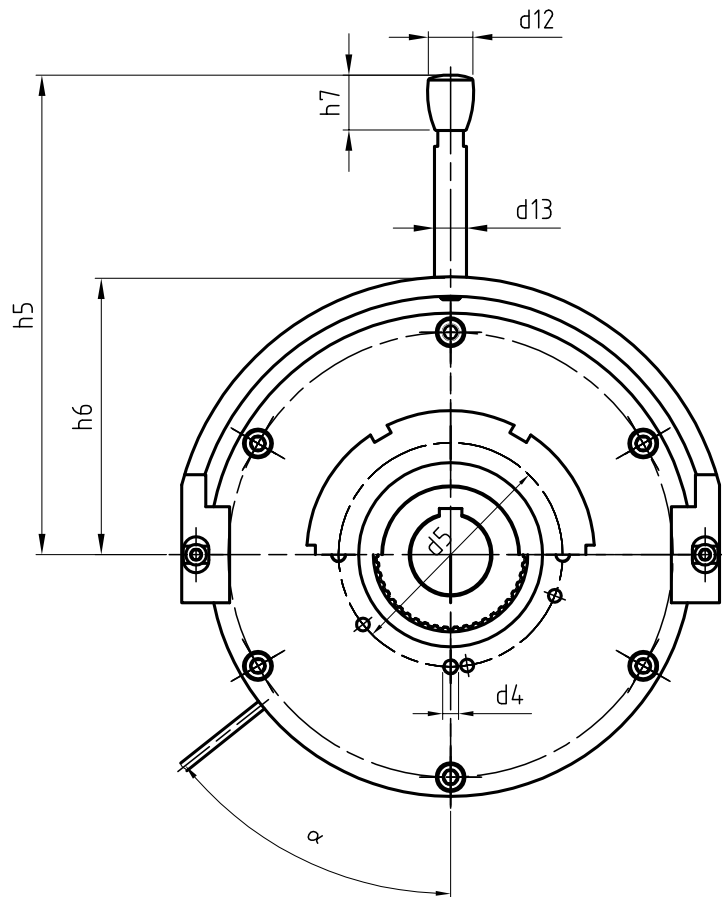

Size	d <sup>H7</sup>	d <sub>1</sub>	d <sub>2</sub>	d <sub>3</sub>	d <sub>4</sub>	d <sub>5</sub>	d <sub>6</sub>	d <sub>7</sub>	d <sub>8</sub>	d <sub>9</sub>	d <sub>10</sub>	d <sub>11</sub>	d <sub>12</sub>	d <sub>13</sub>	d <sub>16</sub>	d <sub>i</sub>	d <sub>a</sub>
18	30/35/40/45	6 x M8	196	75	4 x M8	95	217	217	116	62	77	220	24	14	6 x 9	129	174
20	35/40/45/50	6 x M10	230	85	4 x M10	110	254	254	135	72	90	257	36	20	6 x 11	148	206
25	40/45/50/55/60/65/70**	6 x M10	278	115	4 x M10	140	302	302	180	85	120	305	36	25	6 x 11	199	254
31	80	8 x M16	360	150	4 x M16*	200	390	390	-	-	150	-	-	-	8 x 17	243	330

**Sizes 18-25**

**Size 31**

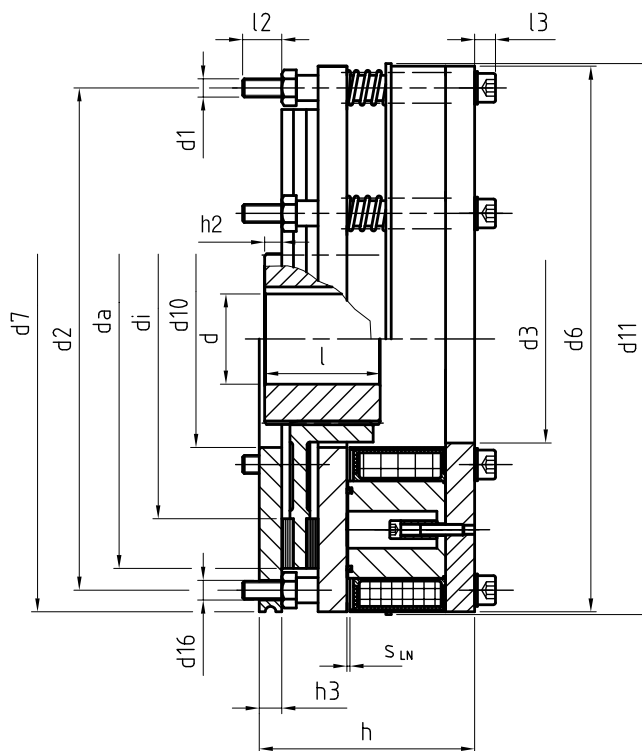
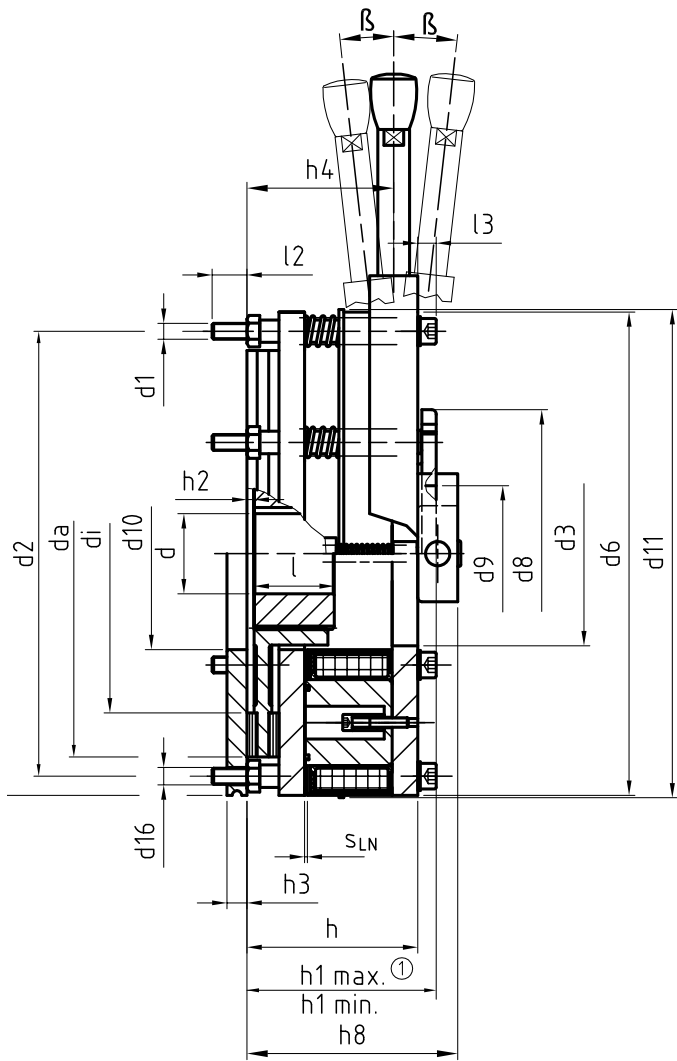

Size	h	h <sub>1</sub> min.	h <sub>1</sub> max.	h <sub>2</sub>	h <sub>3</sub>	h <sub>4</sub>	h <sub>5</sub> max.	h <sub>6</sub>	h <sub>7</sub>	h <sub>8</sub>	l	l <sub>1</sub>	l <sub>2</sub>	l <sub>3</sub>	s <sub>LN</sub>	α	β
18	83,1	89,1	96,5	3	11	70,6	385	128	34	108,1	35	600	15,3	9,6	0,4	54°	8°
20	95,6	105,6	111,6	3,5	11	80,6	650	150	69	120,6	40	600	12,4	12	0,4	54°	8°
25	110,7	121,7	131,7	4,5	12,5	95,7	1045	173,5	69	135,7	50	600	17,3	12	0,5	51,5°	6,5°
31	149	-	-	10	10	Manual release not available					70	600	33	24	0,5	5° -	

d<sub>H7</sub>: Hubs with a keyway as per DIN 6885/1-P9 can only be used for the stated bore diameter (d) up to the max. standard braking torque. Shaft-hub joint designs for higher levels of braking torque must first be clarified with the manufacturer.

Standard keyway as per DIN 6885/1-P9

\* 4xM16, rotated through 45° for display purposes

\*\* Ø 70 mm, keyway as per DIN 6885/3P9

l<sub>1</sub>: Length of the connection cable

m: Mass in kg

All dimensions in mm

## Technical data

### Rated data

Size	P <sub>20</sub> <sup>1)</sup> Hold <sup>2)</sup>	P <sub>20</sub> Release <sup>2)</sup>	S <sub>L max</sub> Up to standard torque [mm]	S <sub>L max</sub> Increased torque [mm]	Max. adjustment [mm]	Min. <sup>3)</sup> rotor thickness [mm]	Aluminium rotor [kgcm <sup>2</sup> ]	Mass of brake cpl. [kg]	Mass of stator cpl. [kg]
18	85	340	1,5	1,0	3,0	10,0	29	19	14,9
20	102	408	1,5	1,0	4,0	12,0	73	32	22,8
25	132	528	1,8	1,2	4,5	15,5	200	50	38,6
31	230	920	2	1,5	3	15	457	85,3	68,8

! P<sub>20</sub>: Coil power at 20 °C in W

! <sup>1)</sup> With holding-current reduction

! <sup>2)</sup> Deviation of up to + 10%, depending on the voltage selected

! <sup>3)</sup> The friction lining is dimensioned in such a way that the brake can be readjusted at least two times

### Braking torques based on speed and permissible limiting speeds

Size	Reference value rated torque at Δn = 100 min <sup>-1</sup> [%]	Braking torque at Δn <sub>0</sub> [rpm]			Max. speed Δn <sub>0max</sub> [rpm]
		1,500 [%]	3,000 [%]	Max. [%]	
18	100	77	70	66	4.400
20	100	75	68	66	3.700
25	100	73	66	66	3.000
31	100	69	–	65	2.300

! As speed increases, so does wear



Whenever and wherever cranes move, INTORQ brakes ensure secure braking and precise stops



**Operating times**

The operating times listed are guide values for DC switching, rated air gap  $s_{LN}$ , warm coil and standard rated torque. The operating times stated are subject to a certain degree of variance. When using AC switching, the

engagement time  $t_1$  is extended by approximately a factor of 5. When using inching mode beyond the overexcitation time of the half-wave bridge rectifier, the engagement time  $t_1$  is also extended.

Torque time characteristic dependent on excitation voltage

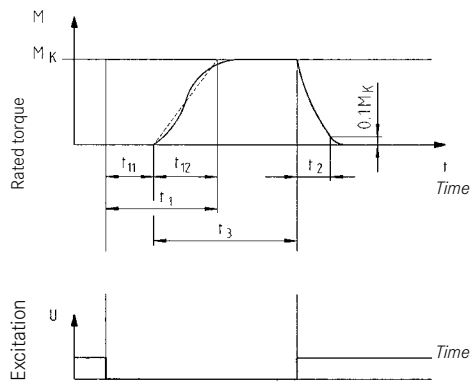

- $t_{11}$  = Delay time on engagement
- $t_{12}$  = Rise time of the braking torque
- $t_1$  = Engagement time
- $t_2$  = Disengagement time
- $t_3$  = Slipping time

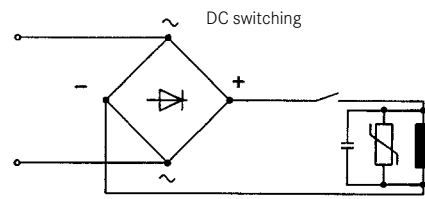
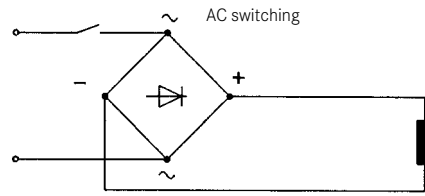

Size	Braking torque rated value for $\Delta n = 100 \text{ min}^{-1}$ $M_K$ [Nm]	Maximally permissible friction energy for one-time operation $Q_E$ [J]	Transitional operating frequency $S_{hue}$ [1/h]	Operating times [ms] <sup>1)</sup>			
				Engagement on the DC side			Release
				[ $t_{11}$ ]	[ $t_{12}$ ]	[ $t_1$ ]	[ $t_2$ ]
18	150	60.000	20	26	30	56	70
20	260	80.000	19	56	112	168	106
25	400	120.000	15	62	135	197	120
31	1200	300.000	13	65	133	198	250

<sup>1)</sup> Operating times valid for 205 V DC coils

## Technical data

### Service life and wear

The friction energy to be expended before the brake needs to be readjusted when reaching  $s_{Lmax}$  depends on various factors, in particular the masses to be braked, the braking speed, the operating frequency and the resulting temperature on the friction linings. As such, it is impossible to state any general values for all operating conditions regarding the friction energy that is expended before readjustment becomes necessary.

Vertical installation also generally generates increased wear.

The BFK468 can be readjusted when the maximum permitted working air gap ( $s_{Lmax}$ ) is reached. The dimensioning of the friction lining allows it to be readjusted at least two times.

Where the amount of friction energy per switching operation is low, the brake's mechanical components can impose limitations in terms of service life. In particular, the rotor/hub connection, springs, armature plate and sleeves are subject to operational wear. The expected service life of the standard design is around 1 million load reversals. Endurance-optimised solutions are available in cases where a longer service life is required (consult the manufacturer).

### Maintenance

Brakes are components which are subject to a great deal of wear. When installing the brake, it is vital to ensure that it can be easily accessed for inspection and maintenance purposes. Intervals between inspections should be set in accordance with the expected service life and load. For more information, please see the operating instructions.

### Permissible friction energy Q based on operating frequency $S_h$

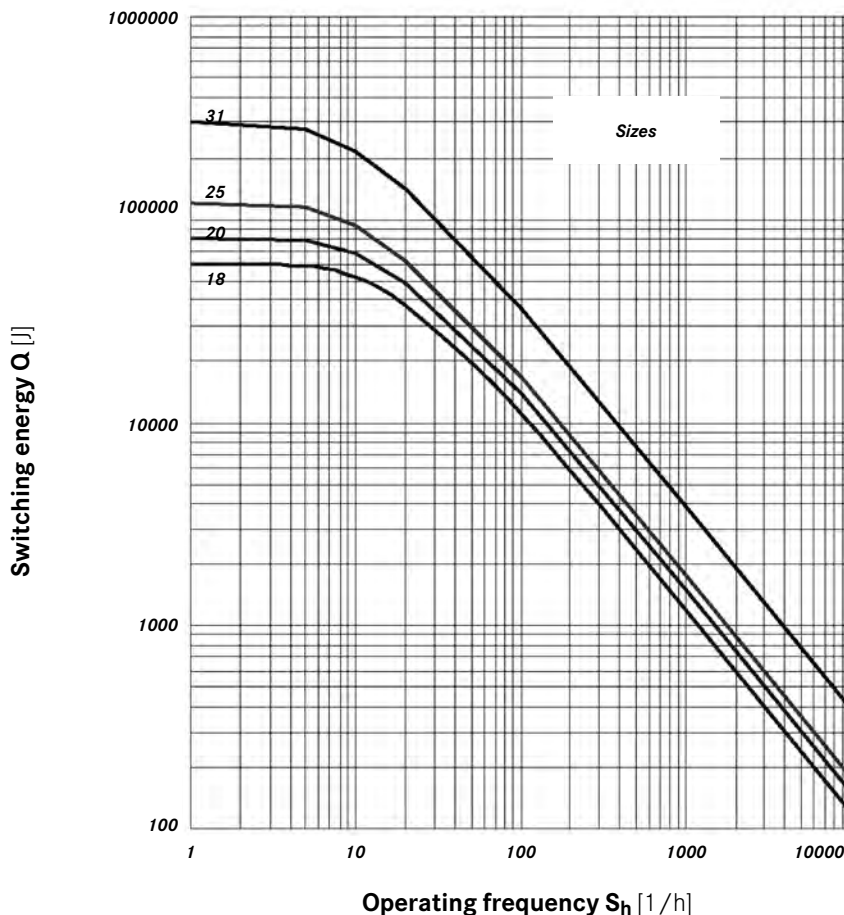

## Accessories

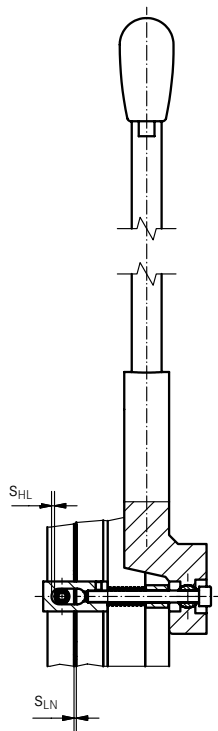

Manual release

### Manual release

The manual release is used to manually release the brake and can also be retrofitted. After being actuated, it automatically springs back into its original position (0-position). The release screws used at the centre of rotation are only subject to tensile loading. The distance  $s_{HL}$  must always be set very carefully during installation of the manual releases:

Size	$s_{LN} \begin{smallmatrix} +0.1 \\ -0.05 \end{smallmatrix}$ [mm]	$s_{HL} \begin{smallmatrix} +0.1 \\ \end{smallmatrix}$ [mm]
18	0.4	2
20	0.4	2
25	0.5	2.5
31	-	-

### Caution:

For safety reasons, the readjustment of the air gap when the mass  $s_{Lmax}$  has been reached must also be performed when using reduced rated torque.

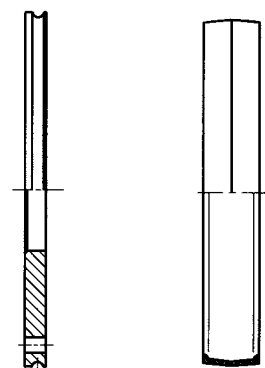

Flange

Seal

### Flange

A flange can be used if no suitable counter friction face is available. The flange can also be fitted with a seal.

### Cover ring

The seal largely prevents any dust, humidity and dirt from getting out of or into the braking area. The seal is inserted into the groove provided on the stator. If no suitable groove is available on the counter friction face, we recommend the use of a flange.

## Accessories

### Brake cover

#### Basic module E, N + cover = encapsulated model

A brake cover can be fitted to basic module E and basic module N to protect the brake from water and dust (IP65 protection). However, the cover cannot be combined with a manual release.

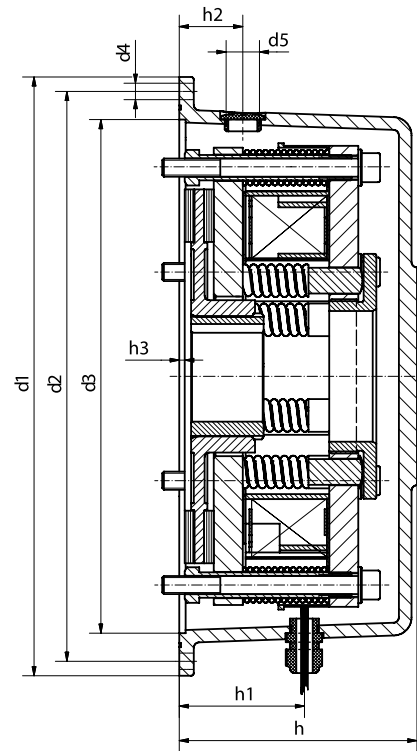

Size	d <sub>1</sub>	d <sub>2</sub>	d <sub>3</sub> H <sup>8</sup>	d <sub>4</sub>	d <sub>5</sub>	h	h <sub>1</sub>	h <sub>2</sub>	h <sub>3</sub> <sup>1)</sup>
18	285	268	238	4 x 6.6	M20 x 1.5	115	60	29	3
20	330	314	283	4 x 9	M20 x 1.5	131	69	35	3
25	390	368	328	4 x 9	M20 x 1.5	142	78	40	3

<sup>1)</sup> Recommended recess length on motor end shield

### Microswitch

The brake can be fitted with a microswitch for the purpose of monitoring the release or wear. The microswitch can be built into the circuit as a normally open or a normally closed contact.

# Half-wave bridge rectifier

## BEG-561-□□□-□□□

The BFK468 models may only be operated with a half-wave bridge rectifier.

The half-wave bridge rectifiers switch from bridge rectification to half-wave rectification after a fixed overexcitation time. Terminals 3 and 4 are connected to the brake's DC circuit, while the induced voltage peak during DC operation (please refer to the circuit diagram entitled "Abbreviated switch-off times") is limited by an integrated overvoltage protection on terminals 5 and 6.



## Dimensions

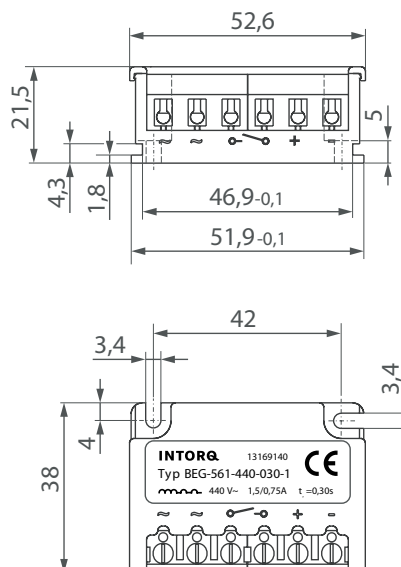

## Technical data

Rectifier type	Forced voltage rectifier
Output voltage with bridge rectification	$0.9 \times U_1$
Output voltage with half-wave rectification	$0.45 \times U_1$
Ambient temperature (storage/operation) [°C]	-25 to +70

$U_1$  = Input voltage (40 to 60 Hz)

Type	Input voltage $U_1$ (40 Hz...60 Hz)			Max. current $I_{Max.}$		Overexcitation time $t_{ue}$ ( $\pm 20\%$ )		
	Min. [V~]	Rated [V~]	Max. [V~]	Bridge [A]	Half-wave [A]	At $U_{rpm}$ [s]	At $U_{1Rated}$ [s]	At $U_{1max}$ [s]
BEG-561-255-030	160	230	255	3.0	1.5	0.430	0.300	0.270
BEG-561-255-130				3.0	1.5	1.870	1.300	1.170
BEG-561-440-030-1	230	400	440	1.5	0.75	0.500	0.300	0.270
BEG-561-440-130				3.0	1.5	2.300	1.300	1.200

# Half-wave bridge rectifier

BEG-561-□□□-□□□

## Fastening options

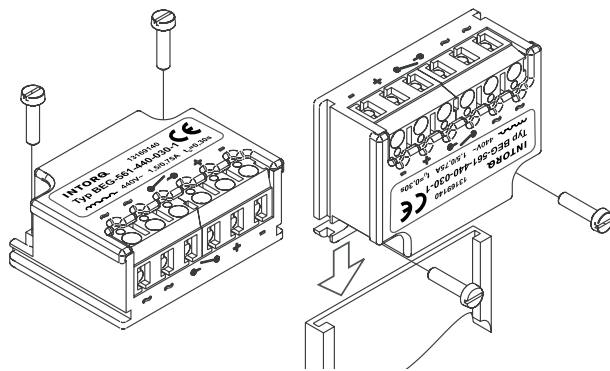

## Permissible current load – ambient temperature

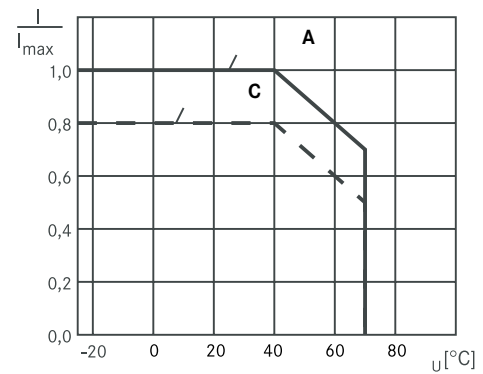

**A** For screw-on installation with metal surface (good heat dissipation)  
**C** For other installation (e.g. adhesive)

## Abbreviated switch-off times

When using DC-side operation (abbreviated switch-off times), the AC-side must also be operated! Otherwise there will not be any overexcitation when switching back on.

## Connection

AC-side switch-off times

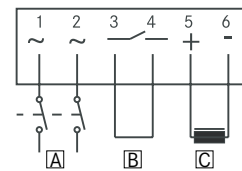

DC-side switch-off times

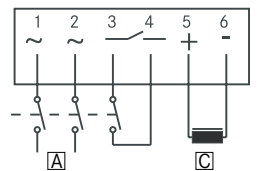

**A** Mains **B** Bridge **C** Coil

## Assignment of the the half-wave bridge rectifiers to the brake size

Brakes type	Rectifiers type	Connection voltage [V AC]	Coil voltage release/hold [V DC]
BFK468-18	BEG-561-255-030	230 +10%	205/103
BFK468-20	BEG-561-255-130		
BFK468-18	BEG-561-440-030-1	400 +10%	360/180
BFK468-20	BEG-561-440-130		
BFK468-25	BEG-561-440-130		
BFK468-31	BEG-561-440-130		



## Noise-reduced designs

The noise reduction required in many applications can be achieved in two ways:

### 1. Impact-noise-reduced armature plate

The brake's operating noise can be minimised using special damping elements, which are installed between the pole face and the armature plate as shock absorbers.

### 2. Noise-reduced aluminium rotor

The rotor with plastic sleeve reduces the rattling noises in the rotor/hub connection. At the same time, this increases the service life of this connection.

## Features and advantages

- ▮ Low rate of wear between rotor and hub
- ▮ Recommended for frequency inverter operation
- ▮ Noise-reduced design
- ▮ Also available in combination with CCV

With size 31, noise is minimised through use of an O-ring between the rotor and hub.

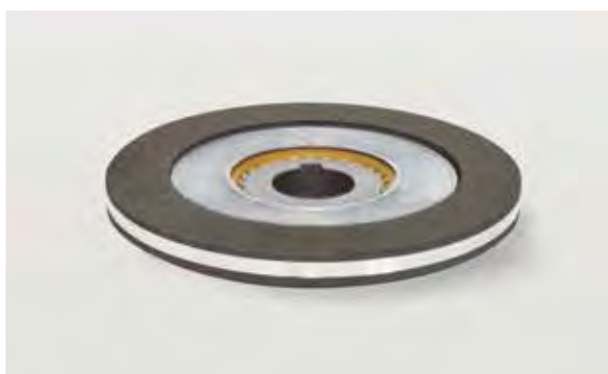

## Product overview

### INTORQ BFK468-□□□

#### Stator, complete

<b>Size</b>	<input type="checkbox"/> 18	<input type="checkbox"/> 20	<input type="checkbox"/> 25	<input type="checkbox"/> 31
<b>Model</b>	<input type="checkbox"/> E (with torque adjustment ring, sizes 18, 20, 25) <input type="checkbox"/> N (without torque adjustment ring)			
<b>Brake voltage</b>	<input type="checkbox"/> 205 V/103 V DC for supply voltage of 230 V AC (not available for size 31) <input type="checkbox"/> 360 V/180 V DC for supply voltage of 400 V AC			
<b>Braking torque</b>	Nm (see torque ratings)			
<b>Cable length</b>	<input type="checkbox"/> Standard (from 100 mm to 1,000 mm in 100-mm steps, from 1,000 mm to 2,500 mm in 250-mm steps)			
<b>Manual release fitted</b>	<input type="checkbox"/> (not available for size 31)			
<b>Armature plate</b>	<input type="checkbox"/> Standard	<input type="checkbox"/> Hard-chrome plated		
<b>Microswitch</b>	<input type="checkbox"/> Monitoring operation (release control) <input type="checkbox"/> Wear monitor			
<b>Operating noise</b>	<input type="checkbox"/> Reduced			

#### Accessories

<b>Rotor</b>	<input type="checkbox"/> Standard	<input type="checkbox"/> Noise-reduced (rotor with sleeve)		
<b>Hub</b>	(Please refer to the dimensions for details on bore diameters)			
<b>Set of fixing screws</b>	<input type="checkbox"/> For fitting to the flange/motor <input type="checkbox"/> For fitting to the flange with through holes			
<b>Sealing</b>	<input type="checkbox"/> Seal (not available for size 31) <input type="checkbox"/> Shaft seal (shaft diameters on request, not available for size 31) <input type="checkbox"/> Cap (not available for size 31)			
<b>Brake cover</b>	<input type="checkbox"/> 18	<input type="checkbox"/> 20	<input type="checkbox"/> 25	

#### Electrical accessories

<b>Half-wave bridge rectifier</b>	<input type="checkbox"/> BEG-561-255-030	<input type="checkbox"/> BEG-561-255-130		
	<input type="checkbox"/> BEG-561-440-030-1	<input type="checkbox"/> BEG-561-440-130		

## Setting standards in the market, worldwide

We are available to our customers at all times and in all locations. Major customers and projects are supported directly by our Key Account Sales Team at our HQ in Aerzen (Germany) or by our locations in Shanghai (China) and Atlanta (USA).

In addition to this, we work with a global network of local trading partners and cooperate with Lenze's global sales organisation.

Please send service requests directly to your local sales partner or to our HQ in Aerzen, Germany:

E-mail [service@intorq.de](mailto:service@intorq.de)

Tel: +49 5154 70534-444

Fax: +49 5154 70534-200

You can find more information on our products, as well as catalogues and operating instructions available for download, on our website at [www.intorq.de](http://www.intorq.de)



