



INTORQ

setting the standard

Electromagnetic brake systems

for lift applications

www.intorq.de

We set the standards

The INTORQ brand stands for reliable brake solutions of the highest standard. Whether in cranes, wind turbines or lift systems – INTORQ products are used in the most diverse of applications. Rely on us to create the right solution for your drive – individually and reliably.

With its broad scope of different versions, the modular range of INTORQ products is used in many motors and geared motors and has set standards worldwide. With the establishment of facilities in Shanghai and Atlanta, we have also consistently expanded our international presence. So wherever you are in the world, our network of sales and service staff is always close at hand to support you.



INTORQ at a glance

- Products: electromagnetic brakes and clutches
- Sales volume € 45 million per year
- 800,000 units per year
- 8,000 m² production area
- Development and production in Aerzen
- Companies in Shanghai and Atlanta
- 200 employees
- 63 sales partners in 49 countries
- Certified to DIN ISO 9001 and DIN ISO 14001



Safety when you need it: Brake systems for lift applications

When using brakes in lift systems, safety is the top priority. We offer you specific solutions for various drive concepts in the field of lift technology.

Whether geared motors or direct drives – our brake systems are precisely matched to your specific requirements. The BFK464-S dual-circuit brake with multi-coil technology has, for example, been optimised for fitting to the new generation of compact direct drives. Also, the kidney-shaped brake callipers of the BFK466 with multi-coil technology have been ideally matched to the contours of axially-short motors and are capable of generating high levels of braking torque.

The most important properties of INTORQ brake systems for lift applications:

- Redundant brake systems
- Long-term reliable noise reduction
- Stable braking torque, even with friction surfaces at high temperatures

Dual circuit spring-applied brakes



INTORQ BFK464-S



INTORQ BFK454

Spring-applied brakes with callipers

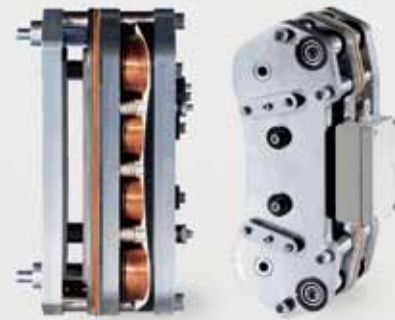

INTORQ BFK466

Double spring-applied brakes



INTORQ BFK455



INTORQ BFK457



INTORQ BFK458

Double spring-applied brake

INTORQ BFK455-28



The powerful double spring-applied brake BFK455-28 is a redundant brake system intended for use in direct drives. Given its flat design this brake can be easily integrated in existing drive solutions.

Properties

- Braking torques of up to 2 x 2065 Nm
- Stable braking torque even with high-temperature contact surfaces
- Noise reduction with long-term stability
- Flat design
- Cost optimized excitation due to bridge/half-wave rectifier (necessary)
- Safe operation as brake circuits are monitored by microswitches
- Manual release optional
- Type tested

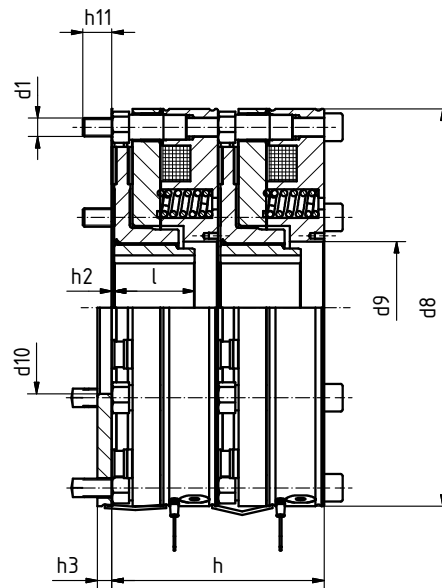
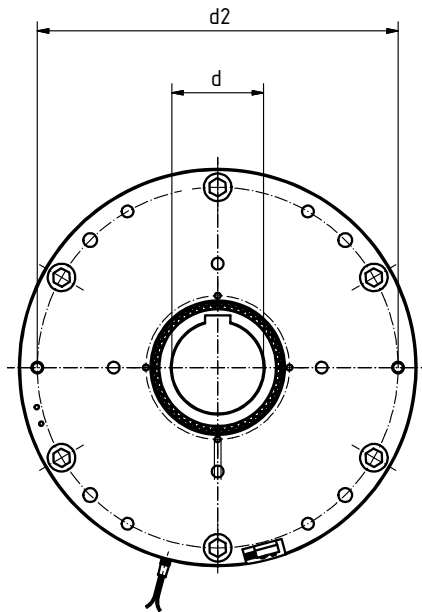

Size	M_k	P_{20} Switch	Hold	d_{J7} 1)	d_{H7} Standard 2)	d_1	d_2	d_8	d_9 H ⁹	d_{10}	h	h_2	h_3	h_{11}	l
28	2x1200	2x434	2x108,5	30	55/65	6xM16	314	346	115	150	185	3,7	12,5	25	85
28	2x1800	2x434	2x108,5	50	70/80	6xM16	314	346	115	150	185	2	12,5	25	70
28	2x2065	2x434	2x108,5	50	70/80	6xM16	314	346	115	150	185	2	12,5	25	70

■ Additional sizes and braking torques on request

■ M_k : Brake rated torque in Nm in relation to $\Delta n = 100$ rpm

■ P_{20} : Coil power at 20 °C in W

■ 1) Predrilled, without keyway

■ 2) Standard keyway according to DIN 6885/1-P9

■ Dimensions in mm

■ More technical information can be found in the operating instructions

Dual circuit spring-applied brake

INTORQ BFK464-S



The dual circuit spring-applied brakes BFK464-S with multiple coil technology are powerful and ideally suited to use in lifts. The required redundancy is achieved by splitting the coil circuits and armature plate.

Properties

- Braking torques of up to 2x900 Nm
- Stable braking torque even with high-temperature contact surfaces
- Noise reduction with long-term stability
- Each armature plate segment can be separately activated using multiple coil technology
- Cost optimized excitation due to bridge/half-wave rectifier (necessary)
- Safe operation as brake circuits are monitored by microswitches
- Manual release optional
- Type tested

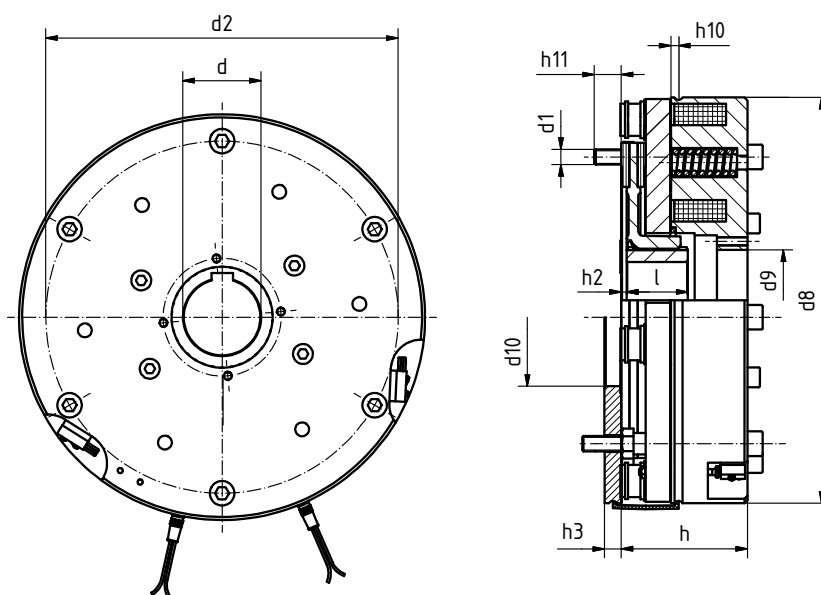

Size	M _K	P ₂₀ Switch	Hold	d ^{H7} Standard ¹⁾	d1	d2	d8	d ₉ ^{H9}	d10	h	h2	h3	h11	l
17S	2x140	2x194	2x48,5	40/45	6xM8	180	200	65	77	71,4	3	11	18,6	50/45
18S	2x225	2x220	2x55	40/45	6xM8	196	226	66	77	74,5	3	11	15,6	50/45
19S	2x280	2x234	2x59	45/50	6xM10	220	246	66	90	77,5	3,5	11	22,6	60/70
20S	2x325	2x256	2x64	50	6xM10	230	265	66	90	82,5	3,5	11	17,6	60/70
22S	2x450	2x282	2x70,5	55/60/65	6xM10	250	277	65	120	86,5	4,7	12,5	23,6	85/50/50
25S	2x600	2x300	2x75	55/60/65	6xM10	278	315	95	120	94,5	4,5	12,5	15,6	85/50/50
28S	2x900	2x404	2x101	70/80	6xM16	314	347	115	150	92,5	2	12,5	27,5	70/70

■ Additional sizes and braking torques on request

■ M_K: Brake rated torque in Nm in relation to Δn = 100 rpm

■ P₂₀: Coil power at 20 °C in W

■ ¹⁾ Standard keyway according to DIN 6885/1-P9

■ Dimensions in mm

■ More technical information can be found in the operating instructions

Spring-applied calliper brake

INTORQ BFK466



Direct drives for modern lift technology require brakes with high braking torques, fast response times and low levels of operating noise. The BFK466 with multi-pole technology satisfies all of these requirements and can also be adapted perfectly to the contour of the motor.

Properties

- Spring-applied brake designed as a calliper
- Redundant by multiple arrangement
- High level of braking torque and large working air gap
- Zero residual torque release and quiet switching
- Optimum contour matching to the motor design
- Cost optimized excitation due to bridge/half-wave rectifier (necessary)
- Fast switching times thanks to low brake inductance
- Release or wear monitoring with microswitch
- Type tested

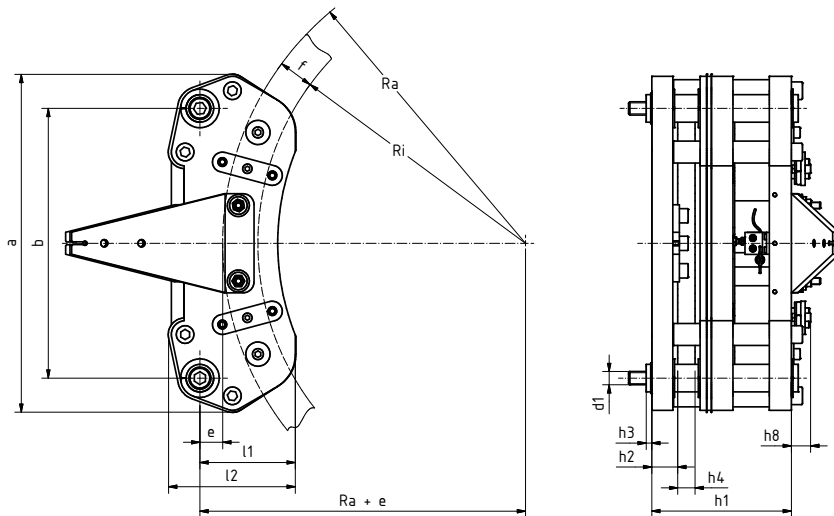

Calculation of rated torque

$$M_K = F_R \times r_0$$

Friction radius

$$r_0 = 2x (Ra^3 - Ri^3) / 3x (Ra^2 - Ri^2)$$

$$Ri = Ra - f$$

Size	Friction force [N]	Power P ₂₀ Switch	Hold	a	b	d1	e	f	h1	h2	h3	h4	h8	l1	l2	Ra min.	Ra max.
12	1172	367 W	92 W	236	206	M10	26	30	101	15	5	15	19	83	98	250	500
22	2240	353 W	88 W	276	220	M10	20	40	108	19	5	15	22	88,6	105	150	425
35	3506	473 W	118 W	307	245	M12	20	32	128	25	5	15	19	87	116	225	375
80	8015	522 W	130,5 W	448	375	M16	25	60	150	29	15	25	-	127,9	165,2	300	600

■ Additional sizes and braking torques on request

■ P₂₀: Coil power at 20 °C in W

■ F_R: rated friction force in relation to a sliding speed of 2m/s

■ Dimensions in mm

■ More technical information can be found in the operating instructions

Dual circuit spring-applied brake

INTORQ BFK454



The dual circuit spring-applied brakes BFK454 satisfy the requirements of TRA 200 and EN-81 for lift systems.

The dual-circuit brake system is achieved by splitting the armature plate in two, the spring force used to generate the braking torque acts

- 80% directly on the front armature plate and
- 20% indirectly via the rear armature plate

Properties

- Braking torques of up to 400 Nm
- Small volume
- Easy adjustment (reduction) of braking torque via the central adjustment ring
- Simple maintenance and monitoring of dual-circuit function
- No division of the rubbing surface

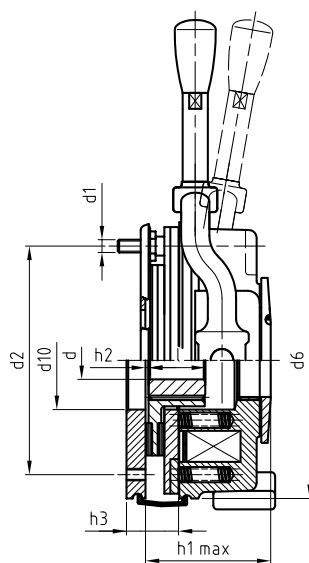
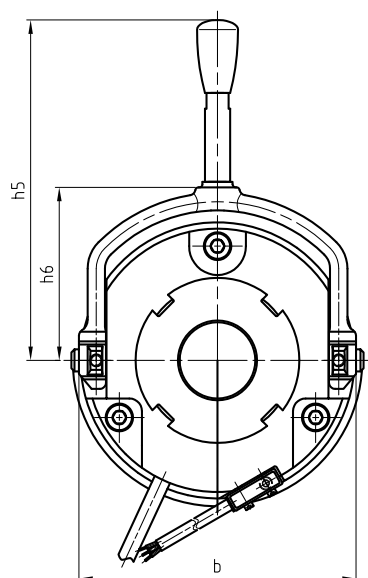

Size	M _K	P ₂₀	b	d J7 pre. 1)	d H7 max. 2)	d1	d2	d6	d10	h1 max.	h3	h5	h6	l
10	15	33	132	10	20	3xM6	112	130	45	60,1	9	134	73,8	20
12	30	40	152	14	25	3xM6	132	150	52	68,5	9	163,5	85	25
14	60	53	169	14	30	3xM8	145	165	55	79,5	11	195,5	98	30
16	90	56	194,5	15	38*	3xM8	170	190	70	87,5	11	240	113	30
18	150	85	222	20	45	6xM8	196	217	77	103	11	347	124	35
20	200	100	258	25	50	6xM10	230	254	90	119	11	418	146	40
25	400	110	302	30	70	6xM10	278	302	120	130	12,5	504	170	50

■ M_K: Brake rated torque in Nm in relation to Δn = 100 rpm

■ P₂₀: Coil power at 20 °C in W

■ 1) Predrilled, without keyway

■ 2) Standard keyway according to DIN 6885/1-P9

* Keyway according to DIN 6885/3-P9

■ Dimensions in mm

■ More technical information can be found in the operating instructions.

Double spring-applied brake

INTORQ BFK457



The switching noise is minimised by the special arrangement of damping elements and thereby achieves values of <50 dbA.

Properties

- Braking torques of up to 2x80 Nm
- Noise-reduced < 50 dbA (as option)
- Modular structure
- Simple mounting using stud bolts
- "Single-handed" manual release

Double spring-applied brakes BFK457 satisfy the high requirements of redundant braking systems in lift systems.

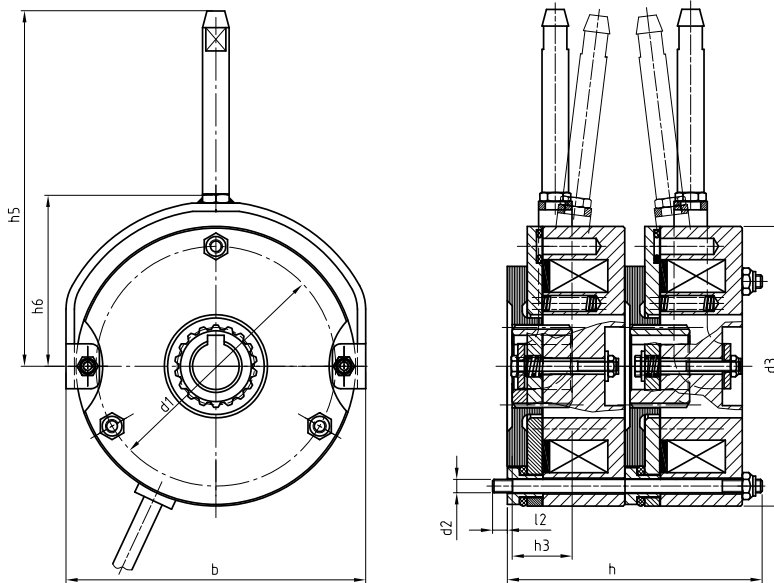

Size	M _k	P ₂₀	b	d J7 pre. 1)	d H7 max. 2)	d1	d2	d3	h	h3	h5	h6	l2
06	2x4	20	90	10	15	72	3xM4	84	75,5	18	109	54	6
08	2x8	25	108	10	20	90	3xM5	102	90,5	20	121,7	62	9
10	2x16	30	137	10	20	112	3xM6	130	102,9	20	147	84	11
12	2x32	40	157	14	25	132	3xM6	150	114,7	25	166	93	11
14	2x60	50	174	14	30	145	3xM8	165	140,5	30	186	106	14
16	2x80	55	203	15	38*	170	3xM8	190	153,1	30	230	120,5	14

■ Additional sizes and braking torques on request

■ M_k: Brake rated torque in Nm in relation to Δn = 100 rpm

■ P₂₀: Coil power at 20 °C in W

■ 1) Pre-drilled, without keyway

■ 2) Standard keyway according to DIN 6885/1-P9

* Keyway according to DIN 6885/3-P9

■ Dimensions in mm

■ More technical information can be found in the operating instructions

Double spring-applied brake

INTORQ BFK458



The redundant brake system this achieves is structured in a modular fashion using the individual components of the BFK458.

Properties

- Braking torques of up to 2x400 Nm
- Noise-reduced (optional)
- Modular structure
- Simple mounting using connection flange
- “Single-handed” manual release

Double spring-applied brakes of the BFK458 series are suited to lifts.

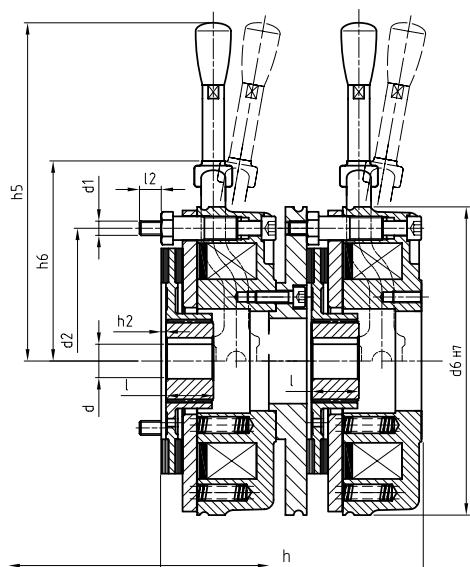

Size	M _K	P ₂₀	d J7 pre. 1)	d H7 max. 2)	d1	d2	d6	h	h5	h6	l	l2
06	2x4	2x20	10	15	3xM4	72	87	84,6	107	56,3	18	8,7
08	2x8	2x25	10	20	3xM5	90	105	97,6	118	65	20	9,8
10	2x16	2x30	10	20	3xM6	112	130	109,8	134	77,8	20	12,7
12	2x32	2x40	14	25	3xM6	132	150	125,8	163,5	88,5	25	13,1
14	2x60	2x50	14	30	3xM8	145	165	148	195,5	101,5	30	13,1
16	2x80	2x55	15	38*	3xM8	170	190	165	240	116	30	16,4
18	2x150	2x85	20	45	6xM8	196	217	186,2	347	128,5	35	17,5
20	2x260	2x100	25	50	6xM10	230	254	215,2	418	149,5	40	17,8
25	2x400	2x110	30	70	6xM10	278	302	236,4	504	175,5	50	21,5

■ Additional sizes and braking torques on request

■ M_K: Brake rated torque in Nm in relation to Δn = 100 rpm

■ P₂₀: Coil power at 20 °C in W

■ 1) Predrilled, without keyway

■ 2) Standard keyway according to DIN 6885/1-P9

*Keyway according to DIN 6885/3-P9

■ Dimensions in mm

■ More technical information can be found in the operating instructions

General information

INTORQ brakes are designed so that the stated rated torques are reliably attained after a short run-in operation.

Given the varying properties of the organic friction linings used and changing environmental conditions, there may however be deviations from the stated braking torques. Appropriate safety factors in the design must take this into account.

An increased breakaway torque may in particular be experienced in damp conditions and with changing temperatures after long downtimes.

The braking torque should be checked when using the brake on the customer's friction surfaces. If the brake is being used solely as a holding brake without any dynamic load, the friction lining must be reactivated regularly.



The INTORQ brand stands for reliable brake solutions of the highest standard. Whether in cranes, wind turbines or lift systems – INTORQ products are used in the most diverse of applications.



We are available to our customers at all times and all locations. Major customers and projects are supported directly by our Key Account Sales Team at our HQ in Aerzen (Germany) or by our locations in Shanghai (China) and Atlanta (USA).

In addition to this, we work with a global network of local trading partners and cooperate with Lenze's global sales organisation.

Please send service requests directly to your local sales partner or to our HQ in Aerzen, Germany:

E-mail service@intorq.de

Tel: +49 (0)5154 705 34-444

Fax: +49 (0)5154 705 34-200

You can find more information on our products, as well as catalogues and operating instructions available for download on our website at www.intorq.de



